

Powerlouvre™

Electrician's Guide

1 Power Requirements

- Low voltage 24V DC current.
DO NOT USE HIGH VOLTAGE - MAX 29V LIMIT.
- 0.4 Amps per motor instantaneous startup current.
- 0.25 Amps per motor constant current.
- 1 motor per bay* in 2-9 blade high windows; 2 motors per bay* in 10-18 blade high windows.

* ('Bay' = grouping of louvre blades, separated by vertical mullions)

- Breezway switch mode transformers available, models suitable for powering up to 6 Powerlouvre motors or 14 Powerlouvre motors.
- Transformers for motor groups larger than 14 Powerlouvre motors can be sourced from electrical wholesalers.
- An Uninterrupted Power Supply (UPS) is available for supplying power to Powerlouvre Windows in the event of a blackout. Transformers can be plugged into this unit and standard wiring guides followed from that point.
- Voltage drop off:
 - Use wire gauge suitable for distance from motor.
 - Voltage below 24v at motors will cause motors to operate slowly.
 - Voltage significantly below 24v at motors will not close the windows completely.

2 Switching/Control

- Polarity of DC current determines movement direction of Powerlouvre motor:
 - o +ve current supplied to +ve wire (white stripe) into Powerlouvre = Powerlouvre window closes.
 - o -ve current supplied to +ve wire (white stripe) into Powerlouvre = Powerlouvre window opens.
- Limit switches on motors prevent current from reaching motors when windows are fully open/closed (continuing to supply current will therefore not harm the system).
- Powerlouvre Windows in Breezway Frames 2-9 blades high have a single pair of wires emerging from the top right corner of the window frame (as viewed from inside the building). This pair of wires is connected to all of the motors controlling all of the blades within the Powerlouvre Window.

- Powerlouvre Windows in Breezway Frames 10-18 blades high have two pairs of wires emerging from the top right hand corner of the window frame (as viewed from inside the building). One pair of wires is connected to all of the motors controlling all of the upper blades within the Powerlouvre Window and is labelled "1", the other pair of wires is connected to all of the motors controlling all of the lower blades within the Powerlouvre Window and is labelled "2". (Check with the window fabricator for wiring details of Powerlouvre Components within window fabricator's frames)
- Multiple Powerlouvre Windows can be controlled by a single switch by wiring the windows together in parallel.

CONTINUE

breezway®

2 Switching/Control Continued



BREEZWAY POWERLOUVRE APPTIVATE™ ADVANCE CONTROL UNIT

- Features & benefits:
 - Touch sensitive wall switch.
 - Smartphone control.
 - Automatic operation in response to timers and built-in temperature sensor.
- Max 12 Powerlouvre motors per control unit.
- Noise passed through some switch mode transformers (eg Meanwell GS40 series) can cause Apptivate Control Units to malfunction. It is recommended that third party transformers are tested prior to purchasing and installation, or that Breezway transformers are used.

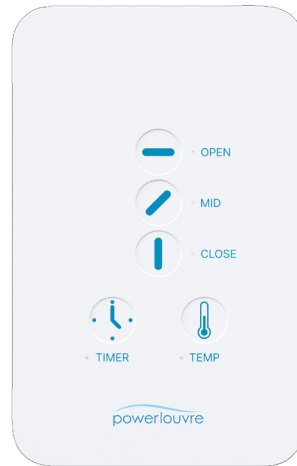

Apptivate Advance Control Unit

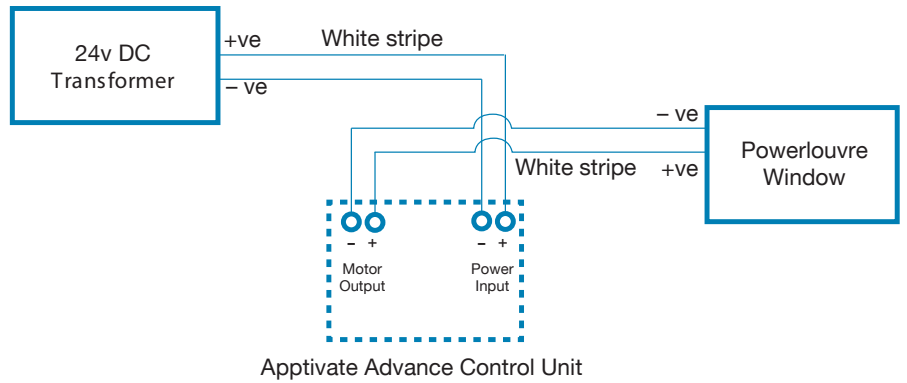

Wiring Example 1

Apptivate Advance Control Unit, single Powerlouvre Window.

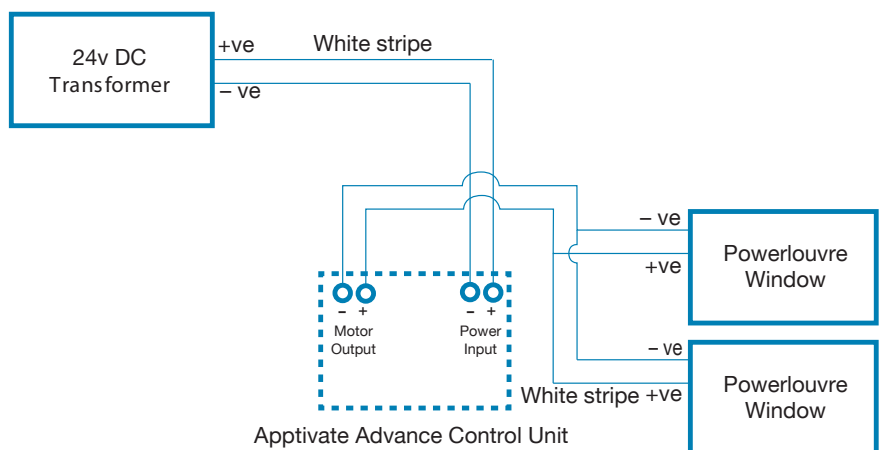

Wiring Example 2

Apptivate Advance Control Unit, two Powerlouvre Windows.



2 Switching/Control Continued

CONTROL OPTION 2

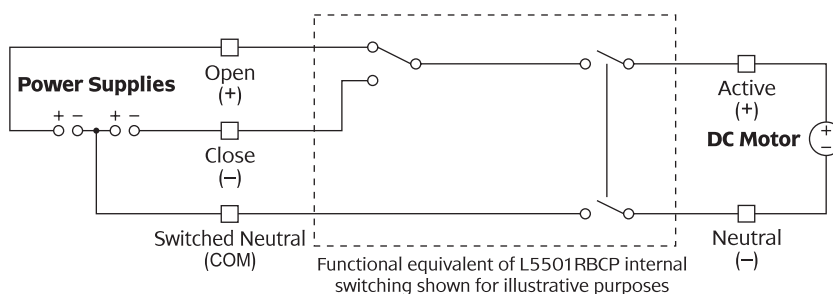

NOTE:

Shutter relay terminal labels are shown as labelled on the product. In this installation their function is not as labelled. A DC termination label is provided for when a DC motor is used.

BUILDING MANAGEMENT SYSTEM

- Features & benefits:
 - o Integration of multiple home systems (eg lighting, blinds, windows, AV)
 - o Integration of external sensors (eg light, rain, wind)
- Reviewed by all major suppliers for compatibility.
- May require relays.
- May require separate transformers to open and to close.
- Powerlouvre Window cannot report it's open/closed status back to the BMS.
 - o Current of appropriate polarity can be supplied for set amount of time to operate Powerlouvre Window.
 - o Example:
 - ♦ If movement from fully closed to fully open takes 14 seconds...
 - ♦ Provide current for 7 seconds to open half way.
 - ♦ Provide current for 20 seconds to open fully (limit switches will prevent damage to motors from supplying current for longer than required).
 - ♦ Provide current for 20 seconds to close fully.
- C-Bus advice
 - o Clipsal advises that L5501RBCP Shutter Relay is simplest Powerlouvre Window to C-Bus interface. (Changeover Relay L5504RVFC is also an alternative, but not Clipsal's recommended option).
 - o Two power supplies are required.
 - o Maximum load of 2A on the Shutter Relay.
 - o Further details <http://www2.clipsal.com/>
 - o Enclosure for Shutter Relay is available – see Clipsal Catalogue (5501RE)

DC Motor Control Fig1.

Figure 1 shows how the L5501RBCP is used with a DC motor. When Open is activated, positive polarity is applied to the motor; when Close is activated, negative polarity is applied. In this configuration two power supplies are required.

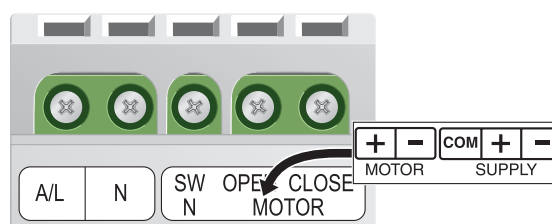

DC Motor Label Fig2.

The terminals of the L5501RBCP are labelled for use with an AC motor. When using a DC motor, attach the provided DC termination label over the factory terminal label. Refer to Figure 2.

CONTINUE

2 Switching/Control Continued

CONTROL OPTION

3

DIY AUTOMATION SYSTEMS (eg Belkin Wemo Maker)

- Features & benefits vary per system, but can include:
 - Control remotely via Wi-Fi
 - Automation in response to Smartphone Applications
- May require relays.

CONTROL OPTION

4

BELL PRESS SWITCHES

- Features & benefits:
 - Simple pair of push-and-hold switches
- Two switches ('Open' & 'Close') required.
- Recommended normally-open, bell-press switches:
 - Clipsal 30MBPR.
 - HPM 770XM.

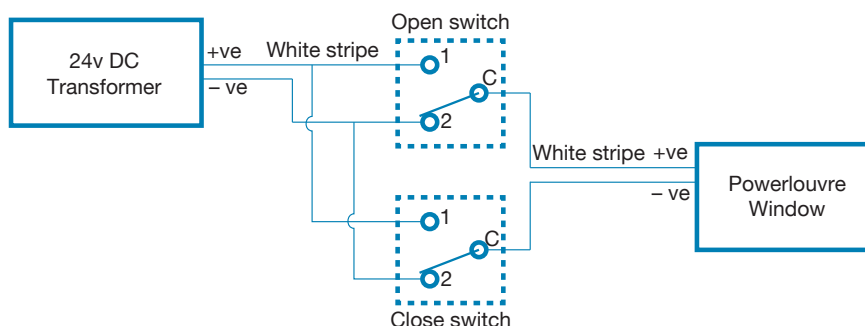

3 Installation

- Wiring emerges from top right (viewed from inside) corner of Breezway Window Frames. (Check with the window fabricator for wiring details of Powerlouvre Components within window fabricator's frames)
- **DO NOT PULL ON WIRES EMERGING FROM WINDOW FRAME**
- Powerlouvre windows can be operated on-site using 18v power-tool batteries without switches – connect wires from Powerlouvre Window directly to battery – change polarity to change direction of operation.
- 24V DC transformers should be installed so that:
 - They are easily accessible.
 - Power cycling of transformers is possible.

4 Maintenance

Maintenance and replacement can be readily carried out during the life of the building.
(see www.breezway.co.nz for care and maintenance instructions.)

breezway[®]