

Breezway Louvre Windows

DESIGN MANUAL

NEW ZEALAND

breezway[®]

Altair® General Information

Altair® Louvre Features	1	Window Sizes	25
Product Performance Warranty	2	Blade Formulas	25
Warranty	3	Fixed Louvre	26
Selecting The Right Aluminium Finish	3	Restricted Openings	27
Louvre Care And Maintenance	4	Security Jamb: 152mm Louvres Only	29
Energy Efficiency and Compliance with Clause H1	5	Aftermarket Security "U" Channels: 152mm Louvres Only	30
Windows Safeguarding Against A Fall Of 1 Metre Or More	6	JMFNZ Timber Frame with Altair™ IGLU™ Louvre	31
Louvre Gallery Features	6	JMFNZ Timber Frame with Altair™ Louvre	31
Standard Heights	7	Checklist	32
Weatherstrip: Standard Height	8	Recommended Specification	32
Weatherstrip: Off Standard Height	8		
Handles	9		
Handle Positions: Altair® IGLU™ Louvre System for 300mm and 500mm Blade Lengths	10		
Handle Positions: Altair® IGLU™ Louvre System for 800mm Blade Lengths	11		
Handle Positions: Altair® IGLU™ Louvre System for 1,127mm Blade Length	12		
Handle Positions: 152mm	13		
Handle Positions: 102mm	14		
Altair® IGLU™ Louvre System	15		
IGLU™ Blades	16		
IGLU™ Window Sizes	16		
Powerlouvre™ Compatibility	16		
IGLU™ Standard Sizes	16		
Powerlouvre™ Window	17		
Operating Conditions	17		
Powerlouvre™ Window Opening Configurations	17		
Powerlouvre™ Window Maintenance	17		
Powerlouvre™ Heights	17		
Electrical Requirements & Wiring	18		
Transformers	18		
Controlling Powerlouvre™ Windows	18		
Uninterrupted Power Supply	18		
Powerlouvre™ Apptivate® Advance Control Unit	19		
Powerlouvre™ Advance App	20		
Powerlouvre™ Advance App	21		
Apptivate® Advance Control Unit Standard Wiring	21		
Building Management System Compatibility	21		
Altair® Louvre Keylock	22		
Off Standard Height Louvre Gallery (Extended Channel)	23		
Glass Blades	23		
Extruded Aluminium Blades	23		
Altair® Louvres with the Stronghold™ System	24		
Compliance with NZBC Requirements: Windows Safeguarding Against A Fall Of 1 Metre Or More	25		

Altair® Louvre Features

Proven cyclone rated performance

Successfully passed test pressures of 8000Pa (simulating wind speeds in excess of 360km/h). Proven performance during Cyclone Yasi in Queensland, Australia.

Widest choice of customising choices

Virtually every aspect of the Altair Louvre can be customised, including colours, handle types, automation, clip types.

Superior design and materials

Altair clips interlock to form a smooth, continuous surface. Automation using the Powerlouvre System where motors and connectors are fully concealed. Non-corrosive, industrial quality materials used exclusively.

Comprehensive testing

Over 150 official tests conducted in audited test rig, many more tests and trials conducted for research and development purposes. All window sizes are tested, test results of small windows are not attributed to larger windows.

Unobstructed views

Horizontal security bars are optional, not mandatory. Unusually shaped or large windows remain fully functional.

Long experience

Breezway has over 85 years of experience designing and manufacturing louvre windows. An active research and development department allows us to be an innovator, not an imitator.

Reputation

Used by most leading window fabricators. Wide support from architects and building designers.

Extruded "T" shaped aluminium operating bars provide a strong, non corrosive, durable and smooth operating mechanism. It also adds extra security as the bars operate to the outside of the channel at all times.

For long and maintenance free use the operating and over centre locking mechanisms are manufactured from non-corrosive material, including all rivets and fasteners.

Injection moulded bearings made of acetal use the living hinge concept to pull the louvre blade against the channel as the window is closed. This results in higher resistance to water and air. Security is now increased by interlocking teeth in the bearing retainer. (Tested to over 40,000 open/close cycles)

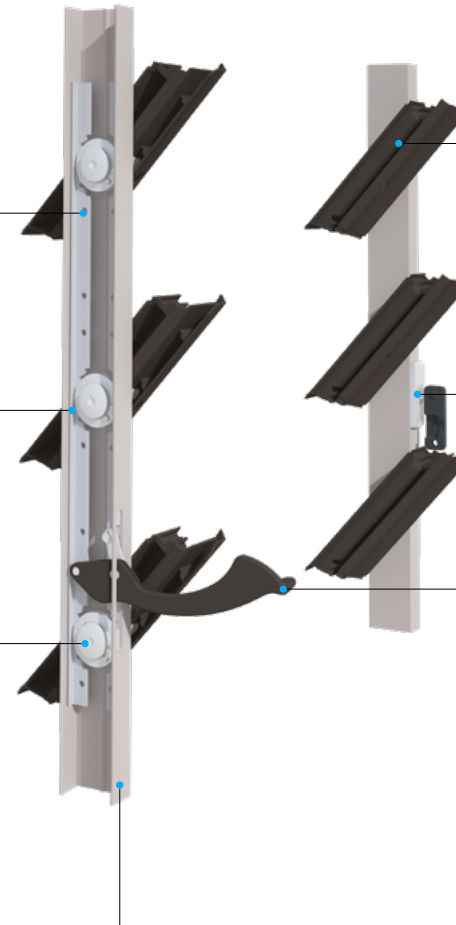

Altair Clips (including Stronghold™ Clips and IGLU™ Clips) are manufactured from UV stabilised polypropylene. The clip colour is solid throughout. Primary and secondary drainage channels within the louvre clips direct the flow of any water to the outside of the building. Colour matching is available for Breezway Standard Colour Range.

Altair keylocks are zinc cast with a brushed chrome finish. The folding key design allows easy operation when installed in frames with deep jambs or reveals.

The handle is made entirely from a UV stabilised acetal. This makes it not only non corrosive, but ideal for commercial areas, as it will spring back to position, even when bent severely. For other handle options see the Altair Handles section. Colour matching is available for Breezway Standard Colour Range.

The Altair Louvre channel is made from 6060-T5 extruded aluminium.

Product Performance Warranty

Altair® Louvres are designed to exceed the requirements of NZS 4211-2008 "Windows in Buildings".

The following table outlines the maximum variations that Breezway® will warrant per Rating Category. Exceeding these constraints will void this Warranty. The limitations have been generated through NATA test results. The design constraints below apply to Altair Louvre Components used in New Zealand manufacturer's framing systems.

For commercial applications, please consult Breezway with your specific project requirements, so we can correctly apply the relevant performance warranty constraints.

A window manufacturer will be able to label its Altair Louvre Window products to comply with NZS 4211 when assembling Altair Louvres to Breezway procedures and operating within the following performance warranty constraints.

	Medium Wind Zone		High Wind Zone		Very High Wind Zone		Extra High Wind Zone	
	960Pa ULS 680Pa SLS 204Pa Water Pass		1360Pa ULS 970Pa SLS 291Pa Water Pass		1760Pa ULS 1250Pa SLS 375Pa Water Pass		2130Pa ULS 1515Pa SLS 455Pa Water Pass	
	Max Span (mm)	Max Height	Max Span (mm)	Max Height	Max Span (mm)	Max Height	Max Span (mm)	Max Height
Altair® IGLU® Louvre								
IGLU glass blade (toughened)	800	21 blades ²	800	18 blades ²	500	11 blades ²	500	11 blades ²
IGLU glass blade (toughened)	1127	15 blades ²	-	-	-	-	-	-
152mm Altair® Louvre								
152mm glass ¹ blade (toughened & annealed)	900	21 blades	700	17 blades	550 ²	15 blades ²	500 ²	9 blades ²
152mm aluminium blade	600	17 blades	450	17 blades	-	-	-	-
102mm Altair® Louvre								
102mm glass ¹ blade (toughened & annealed)	750	33 blades	700	27 blades	-	-	-	-
102mm aluminium blade	600	27 blades	450	27 blades	-	-	-	-

NOTES:

- The Product Performance Warranty only applies to Altair Gallery sets without screw holes.
- Altair Weatherstrips must be used.
- Allowable length of blades have been calculated using AS1288.

1. Glass blades must be 6.0mm ±0.1mm thick and must be straight and flat within 0.3mm/m Glass blades must be 152.00mm ±0.6mm high or 102.00mm ±0.6mm high.
2. High upstand Altair Weatherstrip required.

Warranty

Your louvre windows from Breezway® are warranted against defects arising from faulty workmanship or materials for up to ten (10) years from the date of receipt of goods, provided the following conditions are met.

- a. The product is installed in accordance with the manufacturer's Product Performance Warranty, written installation specification and with all relevant New Zealand Standards.
- b. The product has been maintained according to Breezway and industry recommendations.
- c. The product has not been subject to misuse, physical abuse or neglect.
- d. Manufacturing standards and tolerances are not deemed defects, nor are industry variations in colour of aluminium, plastic and timber componentry.
- e. Breezway accepts no responsibility for glass breakage (except for faulty workmanship or materials).
- f. Aluminium Finishes are guaranteed for ten (10) years.
- g. Moving parts, which wear out as part of normal use, are guaranteed for seven (7) years.
- h. All electrical components are guaranteed for three (3) years.
- i. This Guarantee is limited to the repair or replacement of the faulty product at the company's discretion, but does not extend to the installation or refinishing of a replacement product.
- j. Only repairs carried out by Breezway personnel or authorised agents are covered by this Guarantee.
- k. Claims under this Guarantee should be made within one month of the defect arising in the product. Copies of documentation showing the purchase date of the product should be included with your written claim and forwarded to the nearest Breezway office.

The Guarantee is in addition to all other rights and remedies in respect of this product to which you are entitled under New Zealand law.

Selecting The Right Aluminium Finish

The aluminium components of Altair® Louvre windows are available in three different surface finishes: anodised, standard powder coating and high performance powder coating.

Powder coatings are polyester coatings from leading powder suppliers applied to a thickness of 50 µm and anodised finishes are to a thickness of 25 µm. Over time, weathering of powder coated surfaces should be expected, resulting in a gradual change in appearance. This will be evident in loss of gloss, chalking, colour change and erosion of the powder coatings. Selecting the right powder for the atmospheric conditions of the site and correct maintenance will be critical to the ongoing appearance of the finish.

The application of high durability powder will reduce this deterioration and is essential for severe industrial, coastal or tropical environments.

Note that industry accepted colour variation can occur during the aluminium anodising process.

Louvre Care And Maintenance

Maintaining Aluminium Finishes

Regular maintenance of the surface finish will be necessary to reduce the rate of weathering. The frequency of cleaning will depend on the environmental conditions, but as a guide should be done at 3 monthly intervals, or more frequently in aggressive coastal or industrial environments.

- Remove loose deposits by gently brushing or hosing.
- Clean using a sponge or soft brush and warm water with a mild detergent. Avoid cleaning agents with a caustic base, abrasive materials or harsh chemicals.
- Rinse with clean water.
- Dry with a chamois (optional).

Apply a 'non-abrasive' car polish to maintain the lustre of the finish (optional).

Glass Maintenance

For best results glass blades should be regularly cleaned with mild, non-abrasive detergents. Low e glass blades should be installed with the coated side facing to the inside of the building and should only be cleaned with mild, non-abrasive detergents. Abrasive detergents or cleaning tools will visibly damage the low e coating.

Timber Louvre Blade Finishes

Western Red Cedar blades are a natural material and as such will be susceptible to colour variations and natural movement. Prior to installation or exposure to weather, all timber blade surfaces must be finished with a suitable exterior grade sealant. The finish used should be 'non-tacky' or 'abrasion-resistant' to avoid blades sticking together when closed. Dark colours can cause timber movement. The surface sealant should be re-applied to the sealant manufacturer's instructions to avoid weathering of the timber and minimise timber movement. The product warranty will become void if these actions are not adhered to.

Louvre Maintenance

It is recommended that inspection be carried out at the time of installation and then at yearly intervals. This may be required more frequently depending upon the variation of location, and environmental conditions.

Inspection and checks

- Inspect all fittings and screw fixings for firmness.
- Ensure that all Stronghold™ System pins (if present) are firmly clicked in place.
- Check the louvre clips for any degradation over time.
- Check that the blade is firmly and safely positioned in the clips.
- Ensure all louvre blades operate freely.
- Ensure that seals are in place and clean.
- The Powerlouvre™ Window should be operated at least once per month.

Lubrication

All internal louvre operating mechanisms are pre-lubricated, prior to assembly, with a clear lubricant where required. Under normal conditions this will be satisfactory for the life of the window.

Plastic Maintenance

When cleaning plastic components it is recommended to be done by wetting a cloth with a neutral cleaning agent such as a car wash without wax/polymer, or alternatively a mild furniture polish. Acidic or alkaline cleaning solutions such as vinegar, detergents and glass cleaners should be avoided.

Lock Maintenance

The lock has been designed to be maintenance free besides regular cleaning. If the lock barrel needs to be replaced, for example to change the key types, or if the lock mechanism suffers damage, please contact the window fabricator that supplied the louvre.

Energy Efficiency and Compliance with Clause H1

Breezway® Altair® Louvre Windows can help to enhance the energy efficiency and comfort of a building by offering:

Maximum Ventilation

With no fixed panes and blades that open almost fully horizontally (87°) Altair Louvre Windows welcome fresh, cooling breezes. These cooling breezes reduce the need for power hungry electric air conditioning systems, thereby helping to save our fragile environment.

Tight Sealing

Altair Louvre Windows have an air infiltration rating that is significantly better than the standard required for residential windows. Tight sealing reduces draughts thereby allowing heating and cooling systems to run more efficiently.

Compliance With Clause H1

Compliance with Clause H1 of the New Zealand Building Code is possible in most Climate Zones when Altair IGLU™ Double Glazed Louvre Windows are used.

Altair IGLU Double Glazed Louvre Windows can be used in all climate zones when installed in JMFNZ timber framing under the H1 Schedule Method for housing and buildings over 300m². Compliance can also be achieved through the H1 Calculation Method.

Single glaze Altair Louvres can be used for compliance when using the H1 Calculation Method.

IGLU™ Double Glazed Louvre in JMFNZ Framing R-Values	
Average	Large Size ¹
0.48	0.54

NOTES:

1. Modelled Large Size = 1,800mm(h) x 1,500mm(w).

Windows Safeguarding Against A Fall Of 1 Metre Or More

Restricted Openings

To comply with F4/AS1 2.1.1 or 2.1.2 of the New Zealand Building Code, a 100mm diameter sphere must not be able to pass through the openable window.

Altair Louvre Window Type	Will Prevent A 100mm Diameter Sphere From Passing Through?
Altair Louvre Window with 102mm Clips	Y
Altair Louvre Window with 152mm Clips - unrestricted opening	N
Altair Louvre Window with 152mm Clips - 100mm restricted opening	Y
Altair Louvre Window with 152mm Clips - 80mm restricted opening	Y
Altair IGLU Louvre Window - unrestricted opening	N
Altair IGLU Louvre Window - 72mm restricted opening	Y

Imposed Loads

Altair Louvre Windows have undergone testing to the design loads set out in Clause 3.6 and Table 3.3 AS/NZS 1170.1 "Structural Design Actions" for imposed loads on barrier infills.

In situations where concentrated loads greater than 187N must be withstood Altair Louvres must be specified to include the Stronghold System which mechanically fixes blades into the Altair Stronghold Clips.

AS/NZS 1170 Occupancy	A		A (other), C3, B & E		C1/C2, C5 & D	
Concentrated Design Load (kN)	0.25		0.5		1.5	
Window Position above internal floor	>1200mm	<1200mm	>1200mm	<1200mm	>1200mm	<1200mm
Concentrated Ultimate Load (kN)	0.187	0.375	0.375	0.75	1.125	2.25
Altair Louvre with 6mm toughened glass or Breezway aluminium blade to max blade length 700mm	Y	N	N	N	N	N
Altair Louvre with the Stronghold System with 6mm toughened glass or Breezway aluminium blade to max blade length 700mm	Y	Y	Y	Y	N	N
Altair IGLU Louvre to max blade length 700mm	Y	Y	Y	N	N	N

Louvre Gallery Features

Gallery Type Options

- Single Operating Mechanism
- Powerlouvre™ System
- Key Lock Gallery — not available with: variable keylock positions, additional keylocks or Powerlouvre® options.
- Fixed Louvre Gallery

"Off Standard" Features Available

(No change to manufacturing lead time)

- Right hand control (viewed from inside);
- Top Extended channel to next standard clip size, or cut to length channel for off standard heights;
- Colour matched handles and clips;
- Optional handle Low Profile Handle, Ring Handle (A13);
- 80mm or 100mm restricted opening;
- Variable or additional handle position.

"Standard" Inclusions

- Extruded channel with or without screw holes;
- Single operating mechanism with single left hand control handle (viewed from inside);
- Black handles and clips for all finishes, except white handles and clips for region specific Standard White finishes;
- Standard louvre gallery heights.
- Choice of clips to suit 6mm or 14mm blades.

Standard Heights

Heights for 152mm Blade Louvre Gallery		
No. of Blades	Height (mm) No Weatherstrip	Height (mm) With Weatherstrip
2	320	330
3	460	470
4	600	610
5	740	750
6	880	890
7	1020	1030
8	1160	1170
9	1300	1310
10	1440	1450
11	1580	1590
12	1720	1730
13	1860	1870
14	2000	2010
15	2140	2150
16	2280	2290
17	2420	2430
18	2560	2570
19	2700	2710
20	2840	2850
21	2980	2990

Heights for 102mm Blade Louvre Gallery		
No. of Blades	Height (mm) No Weatherstrip	Height (mm) With Weatherstrip
3	310	320
4	400	410
5	490	500
6	580	590
7	670	680
8	760	770
9	850	860
10	940	950
11	1030	1040
12	1120	1130
13	1210	1220
14	1300	1310
15	1390	1400
16	1480	1490
17	1570	1580
18	1660	1670
19	1750	1760
20	1840	1850
21	1930	1940
22	2020	2030
23	2110	2120
24	2200	2210
25	2290	2300
26	2380	2390
27	2470	2480
28	2560	2570
29	2650	2660
30	2740	2750
31	2830	2840
32	2920	2930
33	3010	3020

Heights for IGLU™ Double Glazed Louvre Gallery		
No. of Blades	Height (mm) No Weatherstrip	Height (mm) With Weatherstrip
2	325	335
3	465	475
4	605	615
5	745	755
6	885	895
7	1025	1035
8	1165	1175
9	1305	1315
10	1445	1455
11	1585	1595
12	1725	1735
13	1865	1875
14	2005	2015
15	2145	2155
16	2285	2295
17	2425	2435
18	2565	2575
19	2705	2715
20	2845	2855
21	2985	2995

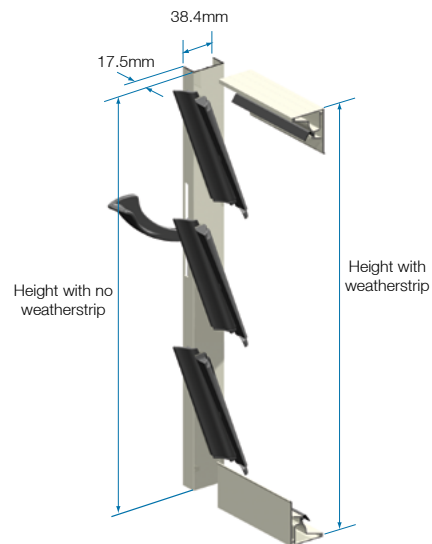

Weatherstrip: Standard Height

- The same Weatherstrip is used on both the head and sill for standard glass and aluminium louvres.
- When water pass pressures greater than 300Pa are required, High Profile Sill Weatherstrips must be used. The High Profile Sill weatherstrip has an upstand 66.5mm high.
- All Altair IGLU Double Glazed Louvre assemblies must use the High Profile Sill weatherstrip.
- Weatherstrip, complete with seal, must be used to gain manufacturer's performance warranty.
- Weatherstrips to head and sill add 10mm to overall gallery height.
- Off Standard Height Galleries that are within 5mm of a Standard Height Gallery will not have a top fixed blade and will therefore require Standard Height Weatherstrip sets.

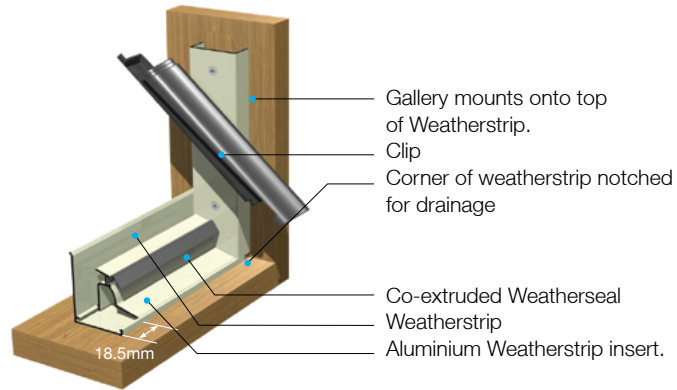

Standard Head

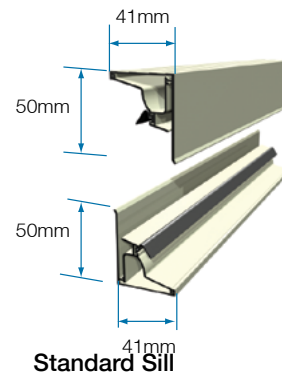

Component Powerlouvre Head

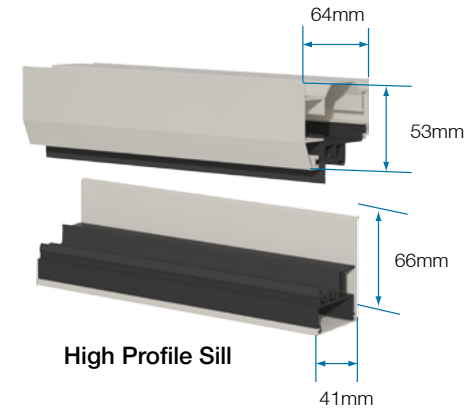

* Weatherstrip inserts for representative purpose only. Inserts are interchangeable, although IGLU Systems use High Profile Sill ONLY

Weatherstrip: Off Standard Height

Used in Conjunction with Extended Louvre Channel

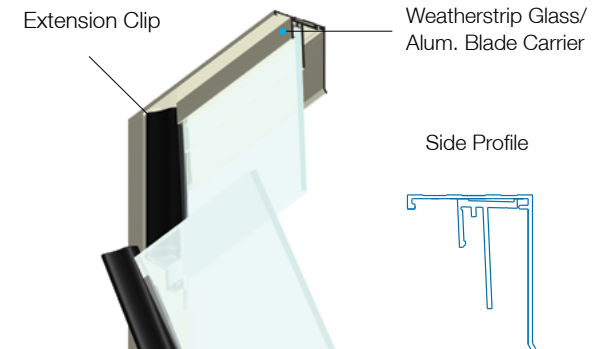
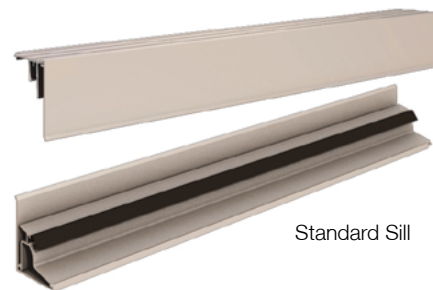

Off Standard Height Head for Glass or Aluminium Blades

- Off Standard Height Galleries that are within 5mm of a Standard Height Gallery will not have a top fixed blade and will therefore require Standard Height Weatherstrip sets.
- Off Standard Height Galleries that are more than 5mm greater than or less than a Standard Height Gallery will have a top fixed blade and will therefore require Off Standard Height Weatherstrip sets.
- Off-standard heights are not available with the IGLU Double Glazed Louvre System.

Handles

Handle Front View

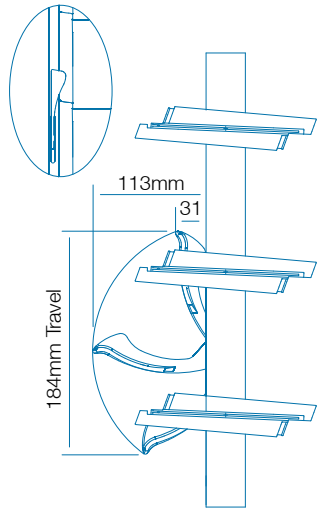

Standard Handle

- Acetal handle
- Ergonomic design for comfortable use

Handle Front View

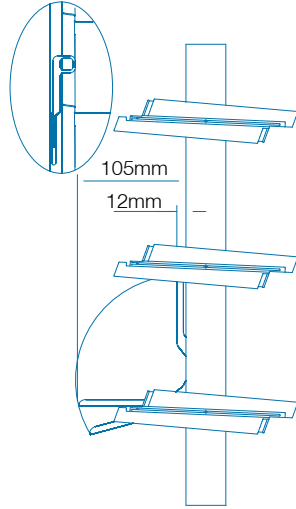

Low Profile Handle

- Stainless steel handle
- Substitute for Standard Handle when inserting into bi-folding & sliding door panels

Handle Front View

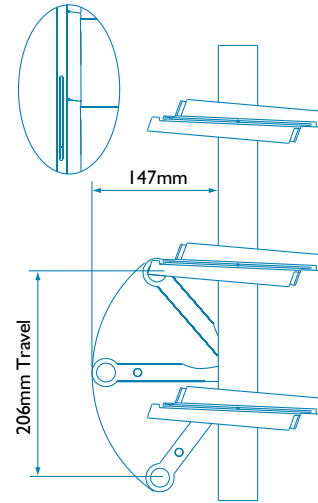

Ring Handle (A13)

- Stainless steel handle for manual operation with Breezway Map Rod when installed out of arm's reach.

Front View: No handle

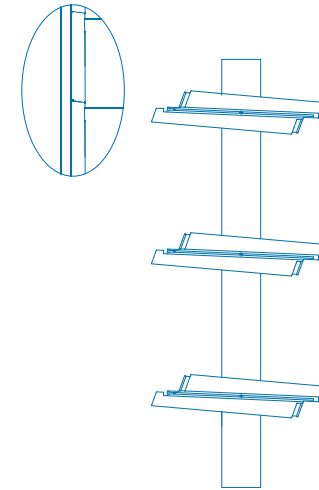

Powerlouvre™ Windows*

- Concealed motors and connectors for use with Remote Window Control Systems

*Keylock not available with Powerlouvre Windows.

Map Rod

- To operate Ring Handle when installed out of arm's reach
- 2m, 3m and 4m set lengths
- 1.8m - 3.6m telescopic length



Handle Positions: Altair® IGLU™ Louvre System for 300mm and 500mm Blade Lengths

Formulas for Other Handle Positions

1. Low Profile Handle Position = Standard Handle Position – 3mm
2. Ring Handle Position = Standard Handle Position +22mm

No. of Blades	Banks of Blades Controlled from Head Downwards	Channel Length	Dim A	Dim B	Dim C	Keylock Positions
2	2	325	77			133
3	3	465	217			273
4	4	605	217			273
5	5	745	217			273
6	6	885	497			553
7	7	1025	637			693
8	8	1165	637			693
9	9	1305	637			693
10	7 3	1445	637	1197		973
11	7 4	1585	637	1197		973
12	7 5	1725	637	1197		973
13	8 5	1865	637	1337		973
14	9 5	2005	637	1477		1113
15	7 8	2145	637	1617		1113
16	7 9	2285	637	1617		1113
17	8 9	2425	637	1757		1113
18	9 9	2565	1057	1897		1533
19	9 4 6	2705	1057	1477	2317	1533
20	9 6 5	2845	1057	1757	2317	1813
21	9 7 5	2985	1057	1897	2457	1953

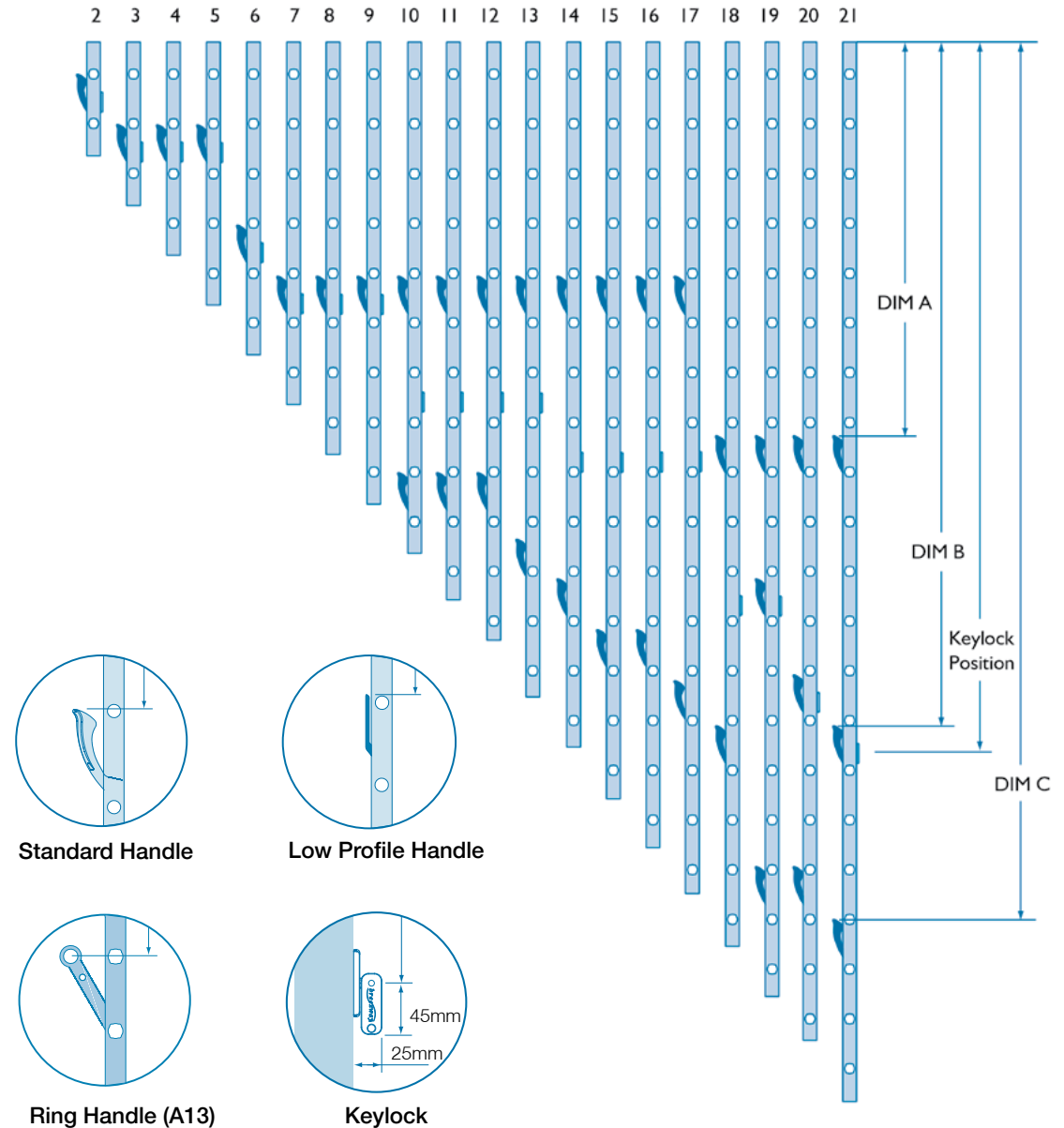

NOTES:

- Additional handles can be specified or relocated to another position. Each handle can operate a maximum of nine clips including at least one clip directly below the handle.
- Relocated keylocks are not available.

Handle Positions: Altair® IGLU™ Louvre System for 800mm Blade Lengths

Formulas for Other Handle Positions

1. Low Profile Handle Position = Standard Handle Position – 3mm
2. Ring Handle Position = Standard Handle Position +22mm

No. of Blades	Banks of Blades Controlled from Head Downwards	Channel Length	Dim A	Dim B	Dim C	Dim D	Keylock Positions
2	2	325	77				133
3	3	465	217				273
4	4	605	217				273
5	5	745	217				273
6	6	885	497				553
7	4 3	1025	217	777			693
8	4 4	1165	217	777			693
9	5 4	1305	217	917			693
10	5 5	1445	217	917			973
11	6 5	1585	497	1057			973
12	6 6	1725	497	1337			973
13	6 4 3	1865	497	1057	1617		973
14	6 4 4	2005	497	1057	1617		1113
15	6 5 4	2145	497	1057	1757		1113
16	6 6 4	2285	497	1337	1897		1113
17	6 6 5	2425	497	1337	1897		1113
18	6 6 6	2565	497	1337	2177		1533
19	6 5 4 4	2705	497	1057	1757	2317	1533
20	6 6 4 4	2845	497	1337	1897	2457	1813
21	6 6 5 4	2985	497	1337	1897	2597	1953

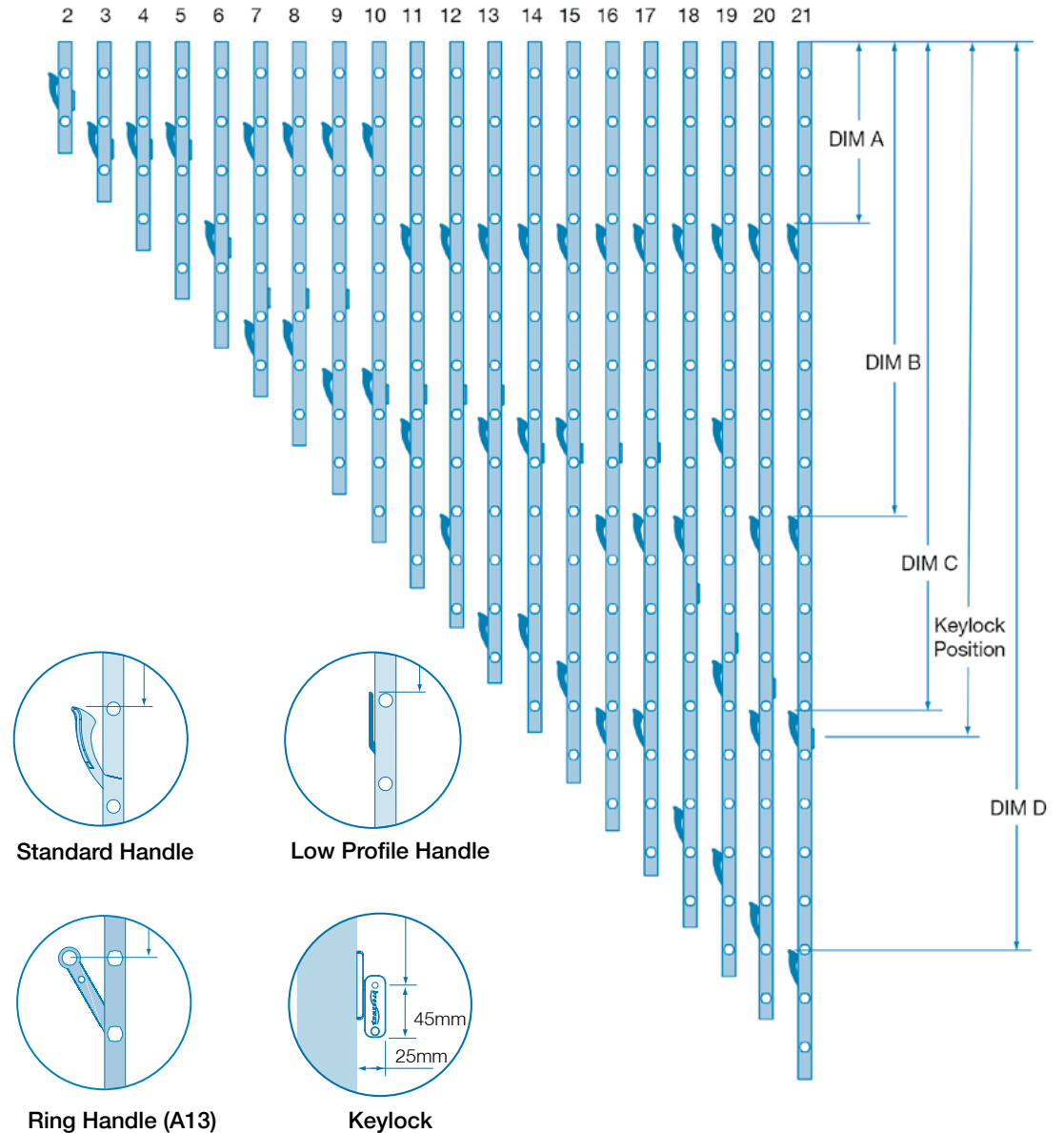

NOTES:

- Additional handles can be specified or relocated to another position. Each handle can operate a maximum of six clips including at least one clip directly below the handle.
- Relocated keylocks are not available.

Handle Positions: Altair® IGLU™ Louvre System for 1,127mm Blade Length

Formulas for Other Handle Positions

1. Low Profile Handle Position = Standard Handle Position – 3mm
2. Ring Handle Position = Standard Handle Position +22mm

No. of Blades	Banks of Blades Controlled from Head Downwards	Channel Length	Dim A	Dim B	Dim C	Dim D	Dim E	Keylock Positions
2	2	325	77					133
3	3	465	217					273
4	4	605	217					273
5	5	745	217					273
6	3 3	885	217	637				553
7	4 3	1025	217	777				693
8	4 4	1165	217	777				693
9	5 4	1305	217	917				693
10	5 5	1445	217	917				973
11	4 4 3	1585	217	777	1337			973
12	4 4 4	1725	217	917	1337			973
13	5 4 4	1865	217	917	1477			973
14	5 5 4	2005	217	917	1617			1113
15	5 5 5	2145	217	917	1617			1113
16	5 4 4 3	2285	217	917	1477	2037		1113
17	5 4 4 4	2425	217	917	1477	2037		1113
18	5 5 4 4	2565	217	917	1617	2177		1533
19	5 5 5 4	2705	217	917	1617	2317		1533
20	5 5 5 5	2845	217	917	1617	2317		1813
21	5 4 4 4 4	2985	217	917	1477	2037	2597	1953

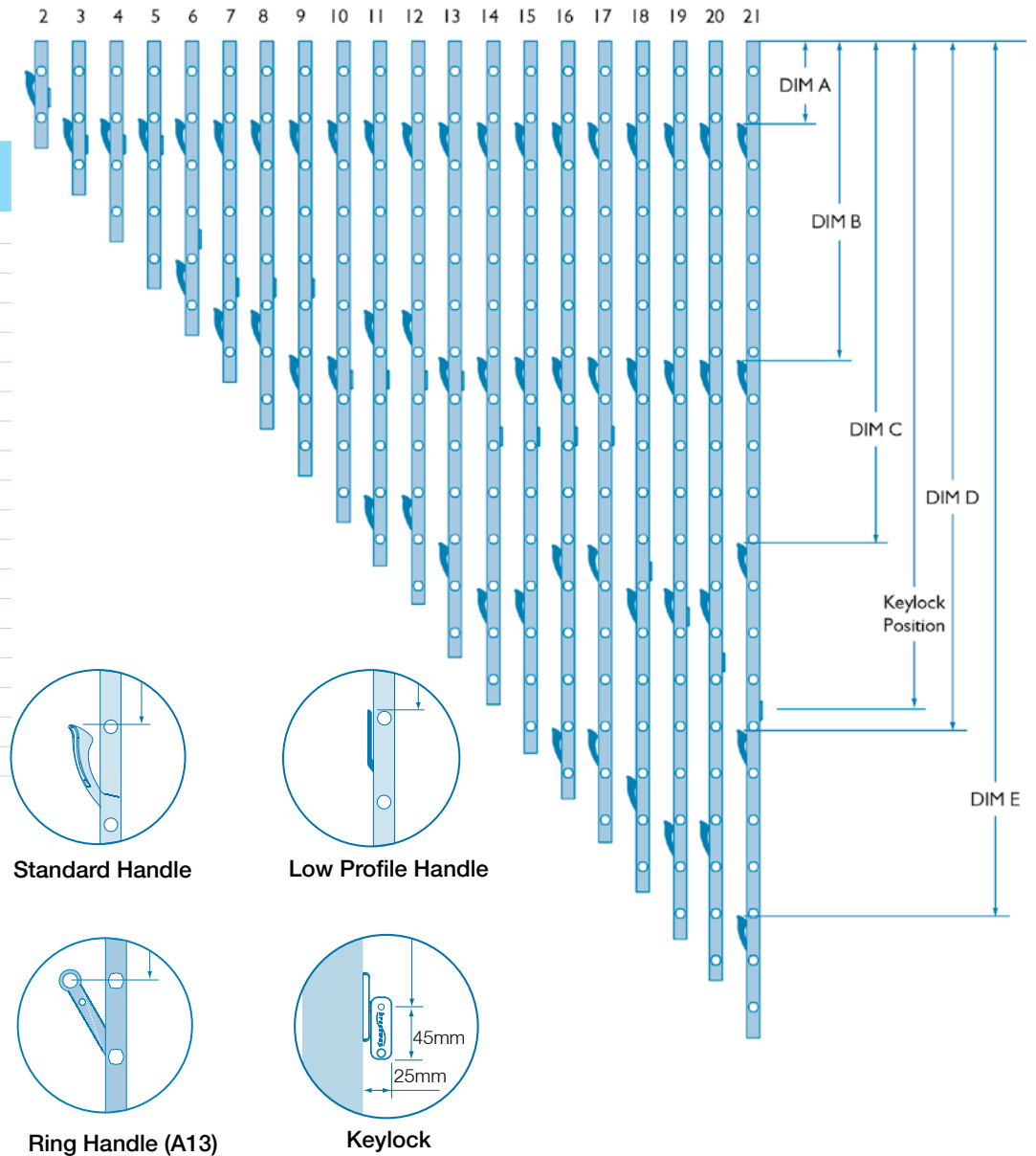

NOTES:

- Additional handles can be specified or relocated to another position. Each handle can operate a maximum of five clips including at least one clip directly below the handle.
- Relocated keylocks are not available.

Handle Positions: 152mm

Formulas for Other Handle Positions

- Low Profile Handle Position = Standard Handle Position – 3mm
- Ring Handle Position = Standard Handle Position + 22mm

No. of Blades	Banks of Blades Controlled from Head Downwards	Channel Length	Dim A	Dim B	Dim C	Keylock Positions
2	2	320	73			128
3	3	460	213			268
4	4	600	213			268
5	5	740	213			268
6	6	880	493			548
7	7	1020	633			688
8	8	1160	633			688
9	9	1300	633			688
10	7 3	1440	633	1193		968
11	7 4	1580	633	1193		968
12	7 5	1720	633	1193		968
13	8 5	1860	633	1333		968
14	9 5	2000	633	1473		1108
15	7 8	2140	633	1613		1108
16	7 9	2280	633	1613		1108
17	8 9	2420	633	1753		1108
18	9 9	2560	1053	1893		1528
19	9 4 6	2700	1053	1473	2313	1528
20	9 6 5	2840	1053	1753	2313	1808
21	9 7 5	2980	1053	1893	2453	1948

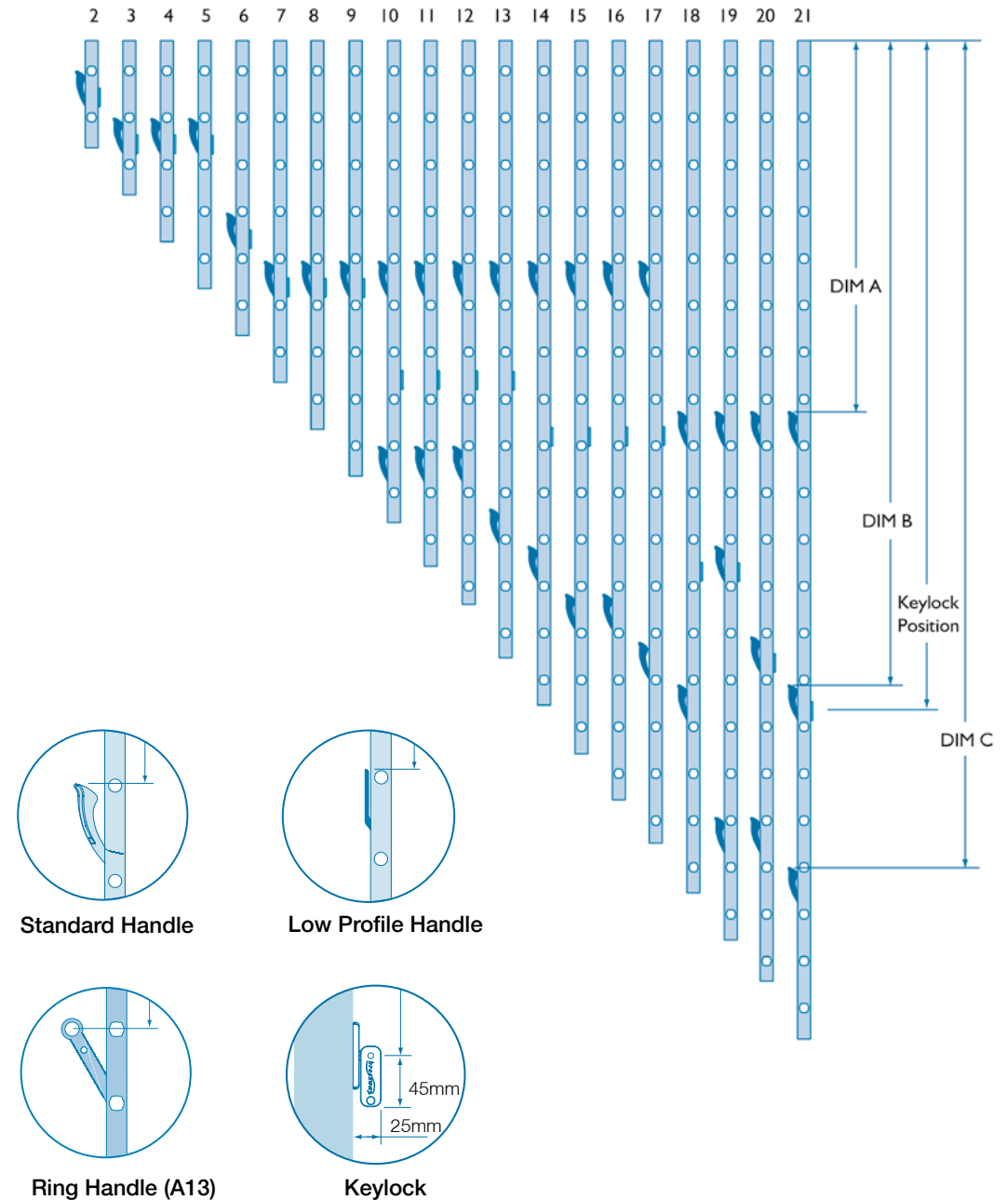

NOTES:

- Additional handles can be specified or relocated to another position. Each handle can operate a maximum of nine clips including at least one clip directly below the handle.
- Relocated keylocks are not available.

Handle Positions: 102mm

Formulas for Other Handle Positions

1. Low Profile Handle Position = Standard Handle Position – 8mm
2. Ring Handle Position = Standard Handle Position +19mm*

* For 3 and 4 blade galleries: Ring Handle position = Standard Handle Position –71mm

No. of Blades	Banks of Blades Controlled from Head Downwards	Channel Length	Dim A	Dim B	Dim C	Dim D	Keylock Positions	
							1	2
3	3	310	90				103	
4	4	400	180				193	
5	5	490	180				193	
6	6	580	270				373	
7	7	670	270				373	
8	8	760	270				373	
9	9	850	270				373	
10	6 4	940	270	720			463	
11	6 5	1030	270	720			463	
12	6 6	1120	270	810			463	
13	6 7	1210	270	810			643	
14	7 7	1300	270	900			643	
15	7 8	1390	270	900			823	
16	9 7	1480	630	1080			823	
17	9 8	1570	630	1080			823	
18	9 9	1660	630	1080			823	
19	9 5 5	1750	630	990	1440		823	1273
20	9 5 6	1840	630	990	1530		823	1273
21	9 5 7	1930	630	990	1530		823	1273
22	9 6 7	2020	630	1080	1620		823	1453
23	9 6 8	2110	630	1080	1620		823	1453
24	9 6 9	2200	630	1080	1620		823	1453
25	9 9 7	2290	630	1080	1890		823	1633
26	9 9 8	2380	630	1080	1890		823	1633
27	9 9 9	2470	630	1080	1890		823	1633
28	9 6 4 9	2560	630	1080	1530	1980	1183	1813
29	9 6 5 9	2650	630	1080	1530	2070	1183	1903
30	9 7 5 9	2740	630	1080	1620	2160	1183	1993
31	9 7 6 9	2830	630	1080	1710	2250	1183	2083
32	9 7 7 9	2920	630	1080	1710	2340	1183	2173
33	9 7 8 9	3010	630	1080	1710	2430	1183	2263

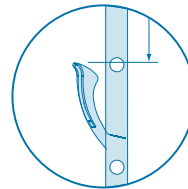
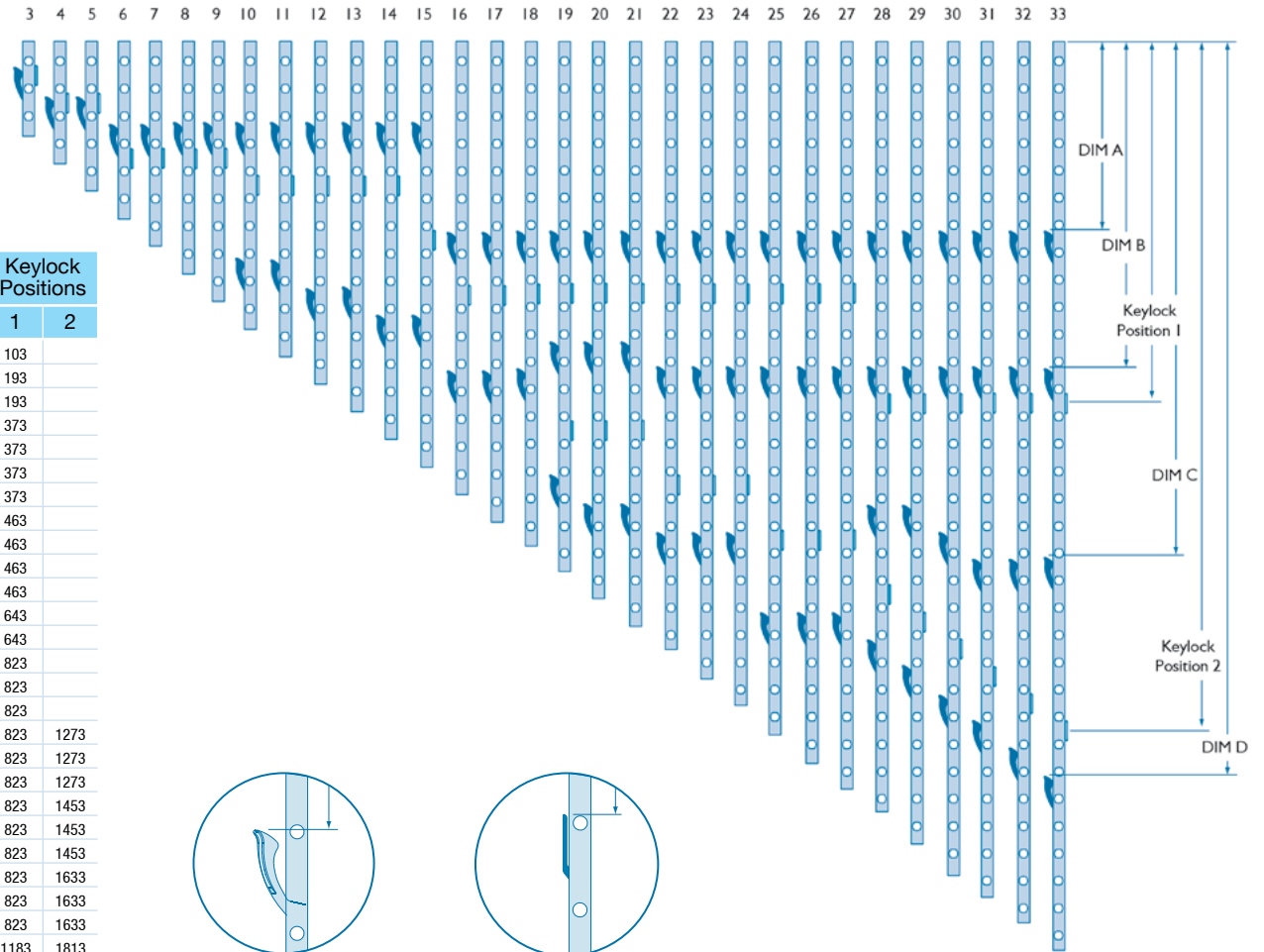

Standard Handle

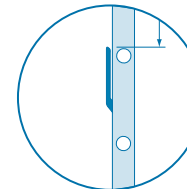

Low Profile Handle

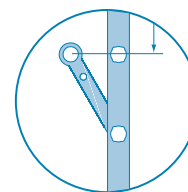

Ring Handle (A13)

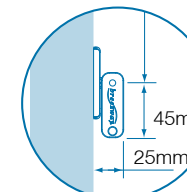

Keylock

NOTES:

- Additional handles can be specified or relocated to another position. Each handle can operate a maximum of nine clips including at least one clip directly below the handle.
- Relocated keylocks are not available.

Altair® IGLU™ Louvre System



NOTES:

- Louvre blades are mechanically retained within the clips by the Stronghold System.

High Energy Performance

The 22mm IGLU™ Blade, comprising of 5mm Low E glazing, 12mm Argon filled spacer, and another layer of 5mm Low E, offers the highest thermal performance of any louvre. This double glazed louvre is ideal for use in colder climates, or anywhere higher levels of thermal insulation are required.

Elegantly Robust Clip

The IGLU™ Clip utilises the Breezway Stronghold™ System, granting superior blade retention, with all the other benefits the Stronghold™ System offers. The stepped nature of the IGLU™ blade allows for the internal glazing layer to be retained, while the outer surface of the clip finishes flush with the outer glazing layer. This allows for a completely flat aesthetic to the outside of the window.

Frameless Glazing

Breezway Altair® IGLU™ Blades are assembled in a way that does not require thermally compromising aluminium framing to each blade. Instead, the blades are capped top and bottom by a blade-to-blade seal, embedded into the Insulated Glazing Unit (IGU) sealant, with a clean ceramic print running the perimeter of each blade to aesthetically conceal the IGU spacer, while still drawing the eye through to the view outside.

Blade Options

IGLU™ Blades come in 4 standard sizes; 300mm, 500mm, 800mm, and 1,127mm. This allows for standard window widths of approximately 400mm, 600mm, 900mm, and 1,200mm in most 3rd party framing systems.

IGLU™ Blades



Stock Blade Sizes

IGLU blades are available in 4 different stock lengths.

- 300mm*
- 500mm
- 800mm
- 1,127mm

These blade sizes allow for standardised window widths, dependent on the framing system used.

* Please note that the 300mm blade span is not available with the Powerlouvre™ System.

IGLU blades comprise of two layers of 5mm toughened Low E with a 12mm Argon filled spacer, and utilise the Stronghold® System for superior blade retention. IGLU spacer concealed behind a mirrored ceramic print.

IGLU™ Window Sizes

Window Size Constraints

The Altair Product Performance Warranty size constraints for Ultimate Limit State Pressure, Serviceability Limit State Pressure and Water Pass must be adhered to in order to ensure compliance with NZS4211.

Standard Heights and Widths

Due to the stock nature of the IGLU Louvre System, standard widths apply as well as standard widths for each system.

Powerlouvre™ Compatibility

Altair IGLU Louvre System is compatible with the Powerlouvre Systems. However, the 300mm blade span is unavailable due to minimum Powerlouvre Window sizes.

IGLU™ Standard Sizes

Standard Height sizes are measured from bottom of visible metal to top of visible metal.

No. of Blades	Breezway™ Altair® IGLU™ System Standard Heights (mm)	
	IGLU™ Galleries with Weatherstrip*	IGLU™ Powerlouvre™ Galleries with Weatherstrip*
2	335	365
3	475	505
4	615	645
5	755	785
6	895	925
7	1035	1065
8	1175	1205
9	1315	1345
10	1455	1485
11	1595	1625
12	1735	1765
13	1875	1905
14	2015	2045
15	2155	2185
16	2295	2325
17	2435	2465
18	2575	2605
19	2715	-
20	2855	-
21	2995	-

*Height without weatherstrip = -10mm for manual, -40mm for Powerlouvre.

Opening Width when using Breezway Altair IGLU Galleries in Component Form

Daylight opening = IGLU Blade Span + 51mm

Powerlouvre™ Window

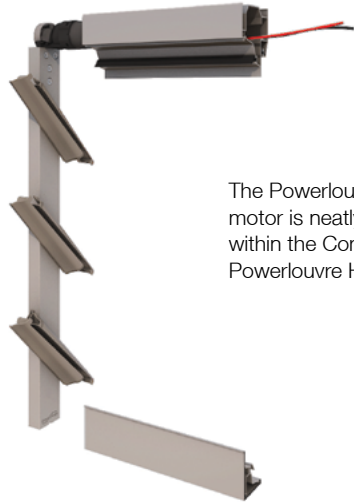

The Powerlouvre Window motor is neatly concealed within the Component Powerlouvre Head Section.

Anticipation of needs

When paired with intelligent control systems, automated Powerlouvre Windows can be opened and closed in anticipation of the building occupant's needs. Unlike manually operated windows which are normally opened and closed only once the building occupant has become uncomfortable.

More frequent use

With operation as simple and easy as the push of a button, Altair Powerlouvre windows will be opened and closed more frequently than windows which require more effort to operate, and therefore the benefits of the windows will be enjoyed more frequently.

Integrated Motor and Gearbox

The Altair Powerlouvre Window incorporates a motor and gearbox concealed within the Component Powerlouvre Head Section, resulting in an automated louvre window with no visible motors, rods or arms.

Variety of Control Options

Control is possible via wall switches, remote control systems or integration into building management systems.

Ease of use

Altair Powerlouvre Windows can easily be operated by young, aged or infirm building occupants.

Operating Conditions

Tests Passed	
Cyclical open / closed	30,000 cycles
Salt mist	1,000 hours
Extreme humidity	90% humidity at 35 °C
Extreme heat	60 °C
Extreme cold	0 °C
Electromagnetic Compatibility	Complies with the requirements of EN61000-6-3 and AS/NZS 4251.1

Powerlouvre™ Window Opening Configurations

Powerlouvre Windows that are 2-9 blades high contain one motor per bay and are wired such that the entire window opens and closes simultaneously.

Powerlouvre Windows that are 10-18 blades high contain 2 motors per bay, one motor drives the blades in the top half of the bay and the other motor drives the blades in the bottom half of the bay.

Breezway® Altair® Powerlouvre Window Opening Configurations		
No. of Blades	Motors per bay	Banks of Blades Controlled from Head Downwards
2	1	2
3	1	3
4	1	4
5	1	5
6	1	6
7	1	7
8	1	8
9	1	9
10	2	5 5
11	2	5 6
12	2	6 6
13	2	6 7
14	2	7 7
15	2	7 8
16	2	8 8
17	2	8 9
18	2	9 9

Powerlouvre™ Window Maintenance

Breezway Powerlouvre Windows should be operated at monthly intervals. Frames should be cleaned periodically as per Breezway care and maintenance recommendations.

Powerlouvre™ Heights

No. of Blades	152mm Altair Powerlouvre Component System Standard Sizes		102mm Altair Powerlouvre Component System Standard Sizes	
	Height including Weatherstrip (mm)	Gallery height excluding Weatherstrip (mm)	Height including Weatherstrip (mm)	Gallery height excluding Weatherstrip (mm)
2	360	320	-	-
3	500	460	350	310
4	640	600	440	400
5	780	740	530	490
6	920	880	620	580
7	1060	1020	710	670
8	1200	1160	800	760
9	1340	1300	890	850
10	1480	1440	980	940
11	1620	1580	1070	1030
12	1760	1720	1160	1120
13	1900	1860	1250	1210
14	2040	2000	1340	1300
15	2180	2140	1430	1390
16	2320	2280	1520	1480
17	2460	2420	1610	1570
18	2600	2560	1700	1660

152mm Powerlouvre Component System

- Off-standard heights between 6mm and 42mm greater than a standard height are not available for 152mm Powerlouvre Component System.
- All other off-standard heights are available.

102mm Powerlouvre Component System

- Off-Standard heights between 1mm and 5mm below a standard frame height are not available.
- Off-standard heights between 6mm and 44mm greater than a standard height are not available for 102mm Powerlouvre Component System.
- All other off-standard heights are available.

Electrical Requirements & Wiring

- Operating voltage: 24V DC
- Maximum allowed voltage: 29V DC
- Maximum constant current: 0.25A per motor
- Maximum startup current: 0.4A per motor
- Opening time: Approx 14 seconds
- Working temperature: -20 to +60 degrees Celsius

NOTES:

In extreme cold conditions the windows will not operate if there is excessive ice build up or if the louvre blades are frozen together.

Maximum Constant Current Requirements

Powerlouvre Window Type	Motors per bay	Maximum Constant Current Required
2-9 Blades High	1	0.25 amps per bay
10-18 Blades High	2	0.5 amps per bay

The direction in which the Powerlouvre Window moves is determined by the polarity of the low voltage current supplied. Once the Powerlouvre Window has fully opened or fully closed, an electronic circuit stops power being delivered to the motors to prevent the motor being damaged should power be supplied continuously.

Transformers

Breezway supplies transformers (as optional extras) that have been specified to meet the particular requirements of Powerlouvre Windows.

- 240V AC input current.
- 24v DC output.
- Sufficient amps to power up to 6 Powerlouvre Motors.
- Built-in overload protection to prevent accidental short circuits from damaging the transformer.

Transformers should be installed in an easily accessible location.

It is recommended that transformers are located in a position that enables easy power cycling.

Controlling Powerlouvre™ Windows

Control options include:

- Breezway Powerlouvre Apptivate® Control Units, which allow control via a touch sensitive wall plate, remote control via a smartphone application, or automatic operation in response to temperature or timer events.
- Building management systems, which allow control along with other automated building products and automatic operation in response to various sensors and inputs.

Uninterrupted Power Supply

Breezway supplies an Uninterrupted Power Supply (UPS) to allow users to continue operating their Powerlouvre Windows in the event of power loss until the UPS battery is depleted. The UPS is connected to and charges from 240V AC power. UPS output is also 240V AC and will require transformers to convert to 24V DC.

Up to 3 transformers can be plugged into the UPS. The quantity of windows that can be powered is dependant on the amperage of the transformers used.

Powerlouvre™ Apptivate® Advance Control Unit

The Powerlouvre Apptivate Control Unit is a plastic, touch-sensitive wall switch.

Features include:

- White, standard sized wall switch.
- Control of up to 12 Powerlouvre Motors on a single Control Unit.
- Fully open, fully close or open to an intermediate (half-open) position at a single touch.
- Precise control of opening angle by touching and then releasing when the window is in the desired position, or by touching another button to stop the window in the desired position.
- Automatic operation in response to an in-built temperature sensor.
- Bluetooth® LE module to allow control by and communication with compatible smartphones.
- Floating appearance, featuring a shadow line around the perimeter of the cover which allows it to visually stand off the wall.
- Wireless communication with the Breezway® Rain Sensor (Coming Soon).

Additional features accessible through the Powerlouvre™ Advance App:

- Remote control.
- Automatic operation in response to an in-built temperature sensor.
- Automatic operation in response to pre-set timers.
- 'Night mode' which adjusts the brightness of LED lights overnight to minimise potential sleep disruptions.
- Over the air firmware updates to the Apptivate Advance Control Unit when updated versions become available.

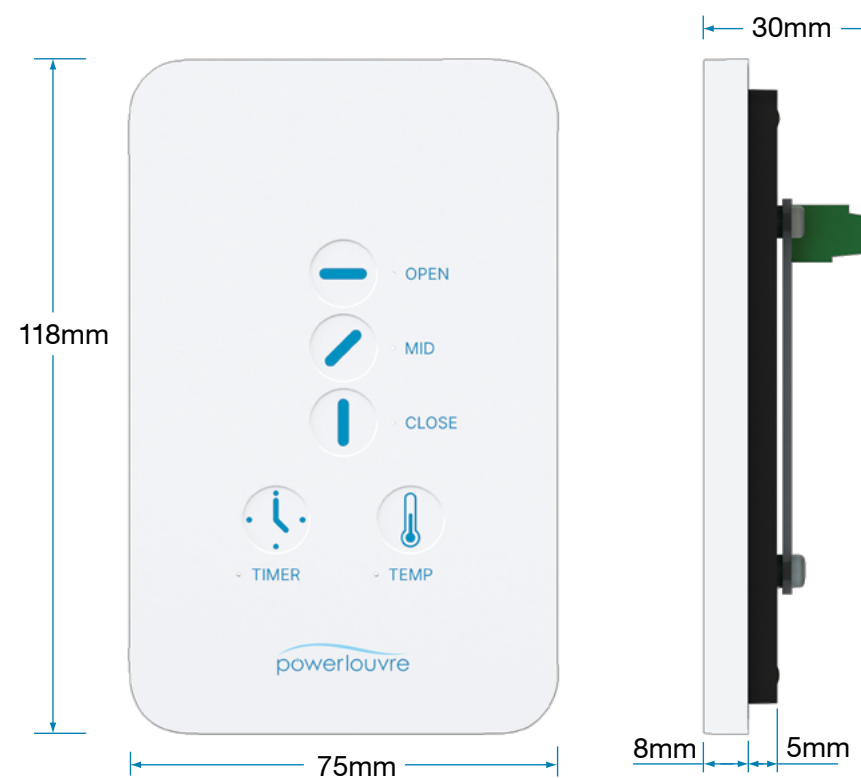

Apptivate® Advance Control Unit

Powerlouvre™ Advance App

The Apptivate® Advance Control Unit includes a Bluetooth® LE module which allows wireless communication between a compatible device running the Powerlouvre Advance App and the Apptivate Advance Control Unit.

Remote control.

The Powerlouvre app enables:

- Remote opening and closing of each Apptivate Advance Control Unit. The range of the Bluetooth signal is approximately 10m - 20m. (The range will be maximised by maintaining a clear line of sight between the device running the Powerlouvre App and the Apptivate Advance Control Unit.)
- Naming of Apptivate Advance Control Units for easy identification.
- An indication of the open/close position of the Powerlouvre Windows connected to each Apptivate Advance Control Unit.

Compatible devices.

Compatible devices will have Bluetooth® LE modules installed and have an iOS or Android operating system.

Devices include:

- Apple products running iOS 12 or newer.
- Devices running Android 10 or newer.

Security.

Establishing associations between the Powerlouvre Advance App and Apptivate Advance Control Units requires:

Close physical proximity between the Powerlouvre Advance App and the Apptivate Advance Control Unit, and;

An access code (defined by the first Powerlouvre Advance App to be associated to the Apptivate Advance Control Unit). For first time connections the PIN will be '0000'.

If the Access Code is forgotten, a factory reset button can be activated by snapping off the front cover plate of the Apptivate Advance Control Unit and hold the reset button down for a 5 seconds. Additionally, holding the reset button for 10 seconds will reset the Apptivate Control Unit to its factory settings.

Security will be maximised by positioning the Apptivate Advance Control Unit in a location that restricts unauthorised access.

Automatic operation in response to temperature.

Temperatures can be set at which the Apptivate Advance Control Unit will:

- Automatically open the windows to naturally cool the room, or
- Automatically close the windows to retain warmth within the room.

Automatic response to temperature can be enabled or disabled:

- Remotely from the Powerlouvre Advance App, or
- Directly on the Apptivate Advance Control Unit.

NOTES:

- As the temperature sensor will be located within the wall cavity it may be susceptible to environmental conditions so the temperature readings will be indicative of the air temperature within the room, but will not exactly reflect the air temperature within the room.



Powerlouvre™ Advance App

Automatic operation in response to timers

Timer events (time of day and day of week) can be set to:

- Open the windows
- Move the window to an intermediate position
- Close the windows
- Begin responding automatically to temperatures.

This allows the windows to be set to operate in anticipation of the building occupant's daily routine. For example, opening before employees arrive to pre-cool the building, or responding to temperatures from when a homeowner goes to bed so that the windows close when the temperature drops in the early hours of the morning.

Timer events can be enabled or disabled:

- Remotely from the Powerlouvre™ Advance App, or
- Directly on the Apptivate® Advance Control Unit.

Control of multiple Apptivate® Advance Control Units

Up to 10 Apptivate Advance Control Units can be associated to each Powerlouvre App allowing building occupants to control windows around their home from their Powerlouvre App. Some mobile devices may have Bluetooth connection limits that reduce this number.

For ease of identification:

- Each of the Apptivate Advance Control Units can be given a customised name.
- The Powerlouvre App will indicate any Apptivate Advance Control Units which are out of range, or with which a Bluetooth® LE connection cannot be made.

For maximum control and ease of use, all the Apptivate Advance Control Units associated to a Powerlouvre Advance App can be operated simultaneously or independantly.

Control by multiple Powerlouvre™ Advance Apps

Associations can be established between multiple Powerlouvre Advance Apps and each Apptivate Advance Control Unit, to allow all family members to control the windows from their smartphones.

NOTES:

- Only one Powerlouvre Advance App will be able to maintain an active Bluetooth® LE connection with an Apptivate Advance Control Unit at any given time. A second device can take control if the initial device is inactive with the screen on for 60 seconds, or 10 seconds if the initial devices screen is off, or the App put to sleep.

Apptivate® Advance Control Unit Standard Wiring

Powerlouvre Motors and Apptivate Advance Control Units require 24V DC power. For ease of wiring the Apptivate Advance Control Unit senses the polarity of the current provided from the transformer and automatically adjusts accordingly.

Up to 12 Powerlouvre Motors can be wired to each Apptivate Advance Control Unit. It is recommended that transformers are located in a position that enables easy power cycling.

NOTES:

- The Apptivate Advance Control Unit is incompatible with some switch mode transformers due to high levels of electrical noise (eg Meanwell GS40 series).

Building Management System Compatibility

The Altair® Powerlouvre Window System has been reviewed for compatibility by the leading suppliers of building management systems. When considering integration into a building management system, the following should be considered:

- Breezway does not supply the various sensors which could be used to instigate opening or closing of the windows (eg temperature or rain sensors).
- Transformer requirements may differ from the requirements of Powerlouvre Windows controlled by Apptivate Advance Control Units.
- The Powerlouvre Window System does not include an inbuilt electronic mechanism to inform the building management system of its current open or close position.
- Powerlouvre Motors include limit switches which prevent the motors from continuing to attempt to open or close the window once the window is fully open or fully closed, thereby preventing damage to the motors and electronics.

Apptivate Advance Control Units are not compatible with building management systems.

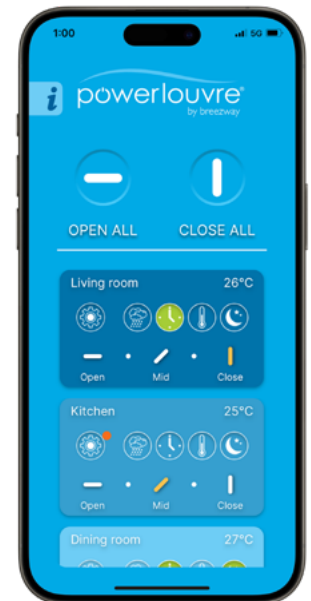

Altair® Louvre Keylock

The Altair Keylock has been designed to be inconspicuous, strong and durable.



Improved aesthetics

Housing the lock mechanisms internally results in a low profile design. The brushed chrome finish suits all aluminium finishes.

Strong and durable

All metal construction and housing the mechanisms internally results in a strong, highly durable lock.

Easy operation with deep jambs or reveals

The folding key design allows easy locking and unlocking even when situated right beside deep jambs or reveals.

Maintenance free

No ongoing maintenance require besides normal cleaning. Tested and passed 15,000 lock & unlock cycles.

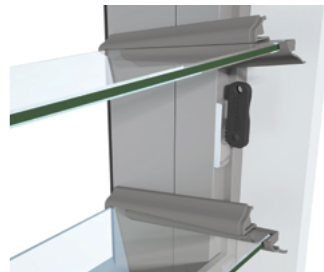

Keylock in unlocked position



Folding key

Off Standard Height Louvre Gallery (Extended Channel)

It is recommended that, wherever possible, Altair® Louvre Windows should be designed to a standard height. This will reduce the product cost and ensure effective opening of all blades.

In some circumstances this may not be possible. In these instances the Altair Louvre can be ordered with Extended Channel. The Extended Channel is a continuation of the channel that is cut to size, giving improved appearance and water performance in comparison to an add-on extension piece.

The Louvre is supplied with an Extended Channel that can be cut back to the required height. Note that the part to be cut down is located at the top of the gallery. All glass blades must comply with the requirements of AS1288 "Glass in Buildings".

Off-standard heights within 5mm of a standard height do not need a fixed blade but the shrouds of the top clips may need to be trimmed for off-standard heights between 5mm and 2mm below a standard height.

Off-standard heights that are not within 5mm of a standard height will be fitted with a top fixed blade.

For example, the louvre illustrated is ordered as 3 blade with Extended Channel.

Off-standard heights are not available with the IGLU™ Double Glazed Louvre System

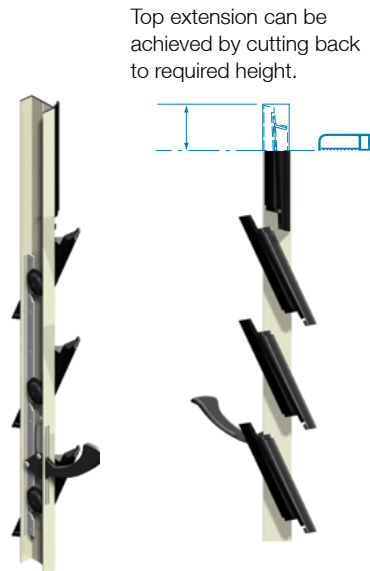

Glass Blades

Exceptional Flatness To Resist Water & Air Infiltration

- Glass blades must be 6mm thick and monolithic. Laminated glass is not recommended for external use due to the risk of de-lamination.
- Exceptional flatness ensures excellent sealing and therefore improved wind and water performances.

Extruded Aluminium Blades

Refined Design

- Breezway aluminium blades feature low profile weatherseals and a clean design at the top of the blade for a minimalist, modern aesthetic.

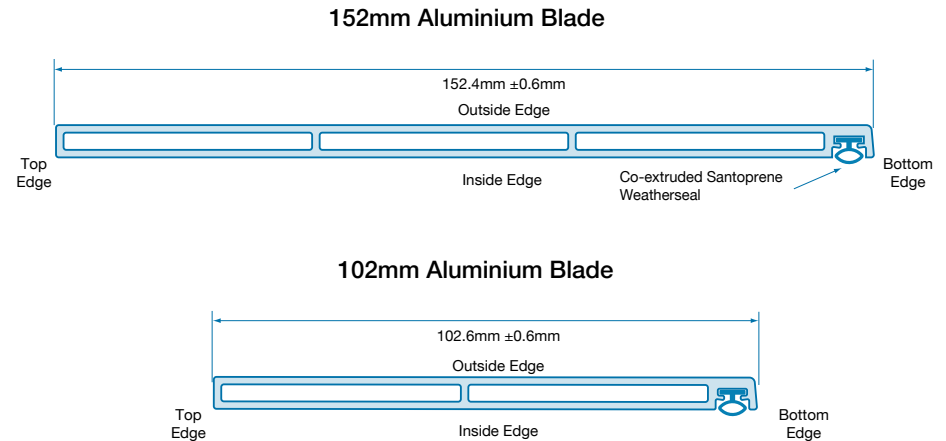

Design Registration applies.

Altair® Louvres with the Stronghold™ System

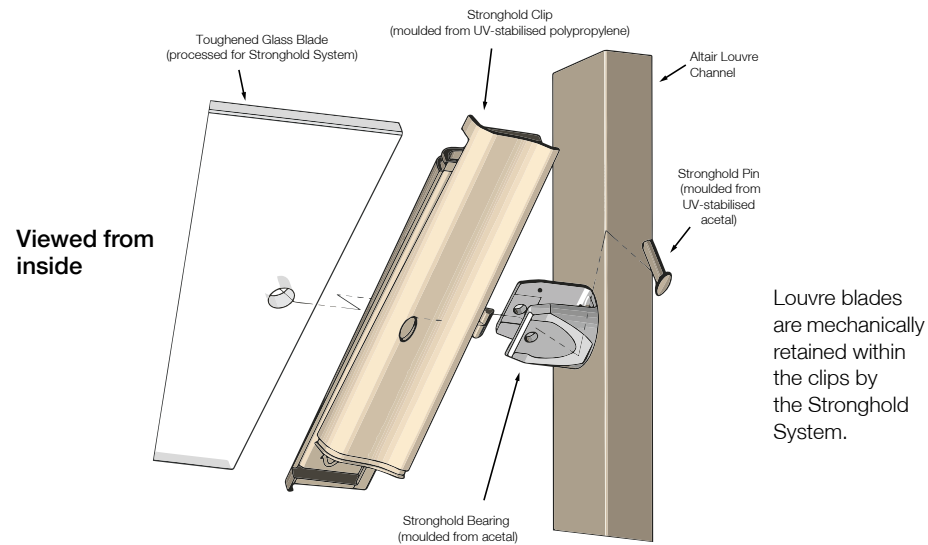

Patented Blade Retention System

Blades are retained in Stronghold Clips by a pin that passes through the clips, bearing and blade. Once installed, the pins cannot be removed without tools and the blades are prevented from being removed from the clips. Pins are visible on the inside/underside of the clips.

Safeguarding Against Falls

Breezway Altair Louvres with the Stronghold System are fit for purpose for locations where openable windows are required to safeguard against a fall of 1 metre or more. As the entire glazed area can be opened to allow airflow they can be used to maximise natural ventilation and cooling in multi level applications. They are also ideal for creating winter gardens as they can be opened for ventilation in warmer weather or closed for protection in colder weather.

Blade Options

Processed and toughened glass and processed aluminium blades can be used in the Stronghold System. The Altair Stronghold System is only available for use with 152mm high blades.

Blade Type Compatibility with the Stronghold™ System

	152mm High	102mm High
Annealed glass	N	N
Toughened glass	Y	Y
Aluminium	Y	Y

NOTES:

Patented design

Compliance with NZBC Requirements: Windows Safeguarding Against A Fall Of 1 Metre Or More

The Altair Louvres with the Stronghold System are windows, not a balustrade system. Altair Louvres with the Stronghold System have been tested to NZS 4211 "Specification for performance of windows" and have completed imposed load testing for barrier infills to AS/NZS 1170.1 "Structural Design Actions". Test reports are available from Breezway. It is the responsibility of the building designer to specify systems and products that meet the barrier and balustrade requirements for a building.

Window Sizes

Window Size Constraints

The Altair Product Performance Warranty size constraints for Ultimate Limit State Pressure, Serviceability Limit State Pressure and Water Pass must be adhered to in order to ensure compliance with NZS 4211-2008.

Standard Heights

The standard heights of Breezway Window Systems with Altair Stronghold Louvres are identical to the standard heights of Breezway Window Systems with regular Altair Louvres.

Off-Standard Heights

It is recommended that, whenever possible, Altair Louvre Windows with the Stronghold System should be designed to a standard height. This will reduce the product cost and ensure effective opening of all blades.

Some off-standard heights are unavailable when using the 102mm Altair Louvre Galleries with the Stronghold System.

Unavailable Off-Standard Heights when using 102mm Altair Galleries with the Stronghold System

Altair Component System

Standard height + 19mm to standard height + 30mm



Maintenance

The Breezway Louvre Care and Maintenance recommendations must be adhered to.

If blades need to be removed from an Altair Louvre with the Stronghold System or if broken blades need to be replaced, the pins must be removed. The removal process requires tools and will destroy the pins so new pins will be required when blades are re-installed.

Powerlouvre Compatibility

The Stronghold System are fully compatible with the Powerlouvre Systems and have no impact on minimum and maximum Powerlouvre Window sizes.

Blade Formulas

Blade Cut Length Standard Jamb

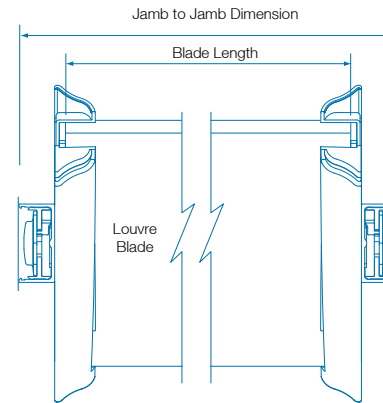

Glass & aluminium blades:

Blade Length = jamb to jamb – 52mm

Stronghold toughened glass & aluminium blades:

Blade Length = jamb to jamb – 48mm

IGLU Double Glazed blades:

Blade Length = jamb to jamb – 51mm

Blade Cut Length Breezway® Security Jamba

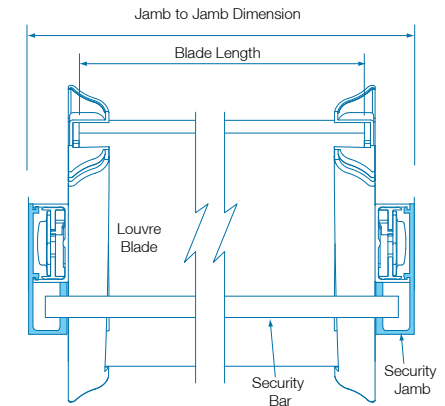

Glass & aluminium:

Blade Length = jamb to jamb – 56mm

IGLU Double Glazed blades:

Blade Length = jamb to jamb – 55mm

Component Form — Manually Operated

Glass & Aluminium blades x = Channel extension +20mm

Component Form — Powerlouvre®

Glass & Aluminium blades x = Channel extension +12mm

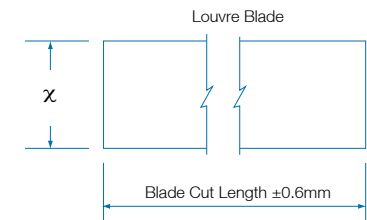

Extension Blade Dimensions

For allowable length of blades refer to AS1288 and Breezway Louvre Windows's PRODUCT PERFORMANCE WARRANTY.

Note: Allowable tolerance = +/-0.6mm

Fixed Louvre

No. of Blades	Height (mm) No Weatherstrip	Height (mm) With Weatherstrip
3	310	320
4	400	410
5	490	500
6	580	590
7	670	680
8	760	770
9	850	860
10	940	950
11	1030	1040
12	1120	1130
13	1210	1220
14	1300	1310
15	1390	1400
16	1480	1490
17	1570	1580
18	1660	1670
19	1750	1760
20	1840	1850
21	1930	1940
22	2020	2030
23	2110	2120
24	2200	2210
25	2290	2300
26	2380	2390
27	2470	2480
28	2560	2570
29	2650	2660
30	2740	2750
31	2830	2840
32	2920	2930
33	3010	3020

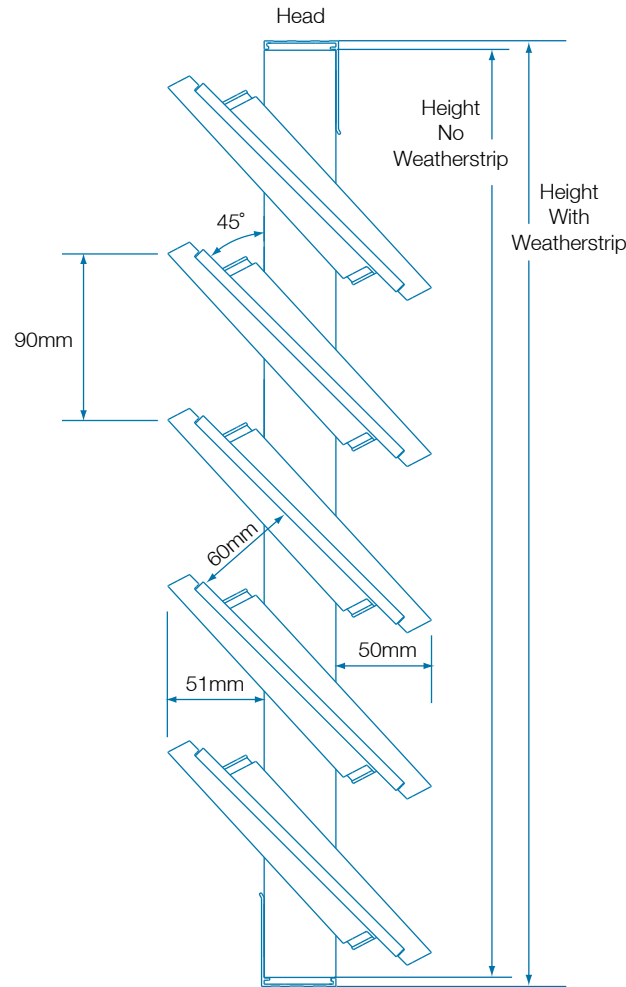

152mm Fixed Louvre

NOTES:

- Not Available in 102mm
- This product does not meet NZS 4211 water penetration requirements.
- Fixed louvres are only available in standard heights ie. extended channel not available.

Applications for Fixed Vent Louvres

Use fixed vent louvres where permanent ventilation, light, privacy and a degree of weatherproofing is required. Some typical applications include:

- Vented roofs
- Laundries (industrial, domestic)
- Bathrooms
- Public Amenities
- Housing for air conditioning units

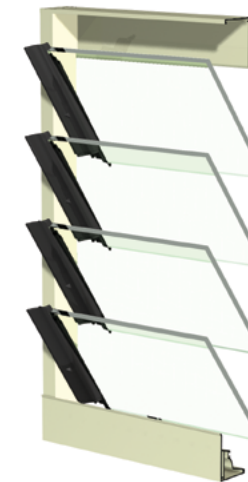

Restricted Openings

Altair Louvre Windows can be restricted to only allow a nominal opening of 80mm or 100mm between open single glaze blades, and 72mm between IGLU™ double glazed blades.

Restricted openings can be used to prevent clips from impacting screens in some frames, or to limit the size of objects able to pass through the open window.

*178mm when clips to suit 14mm thick blades are used.

**69mm when clips to suit 14mm thick blades are used.

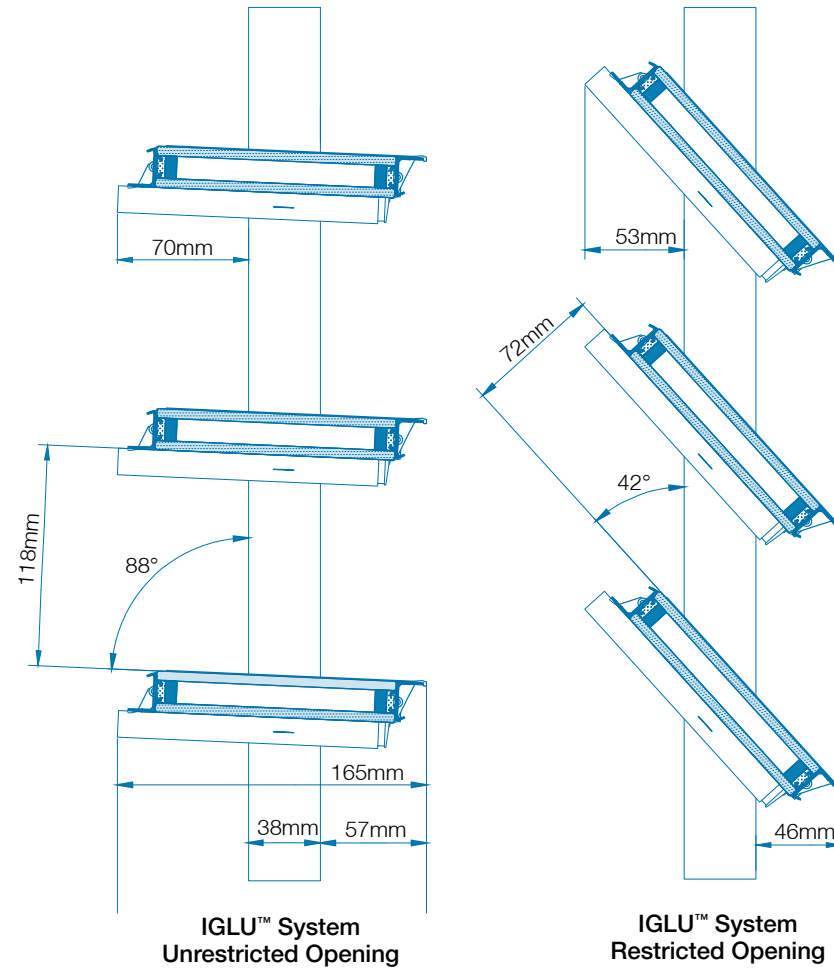

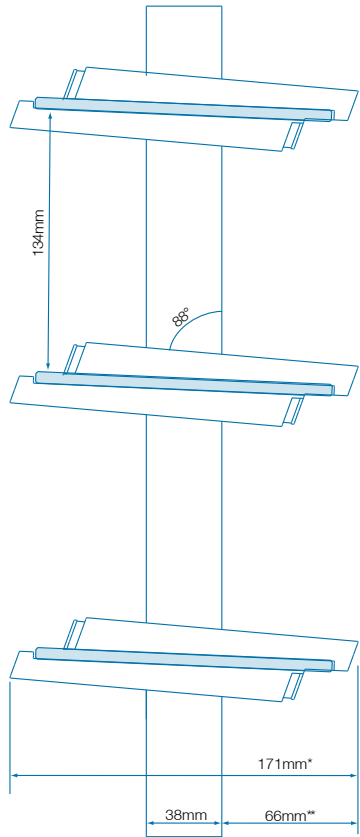

**152mm Louvre
Unrestricted Opening**

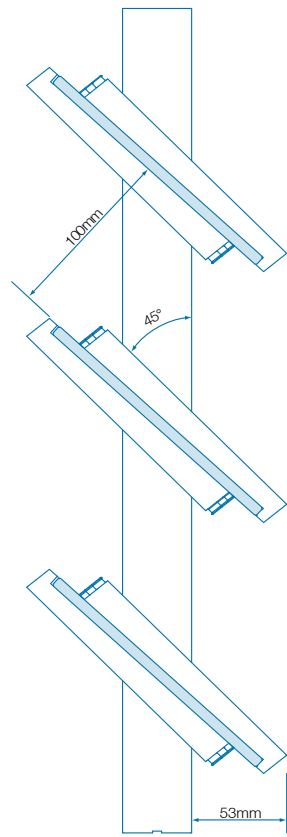

**152mm Louvre
100mm Restricted Opening**

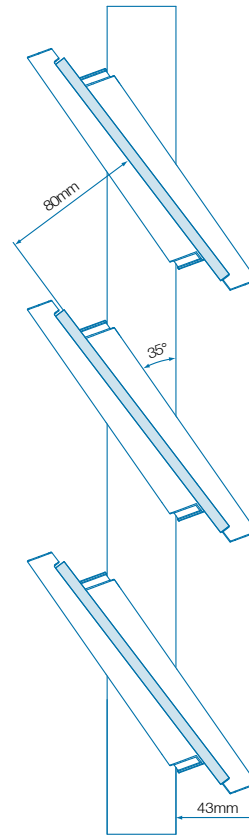

**152mm Louvre
80mm Restricted Opening**

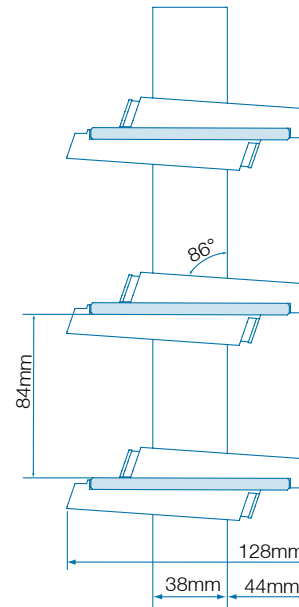

**102mm Louvre
Unrestricted Opening**

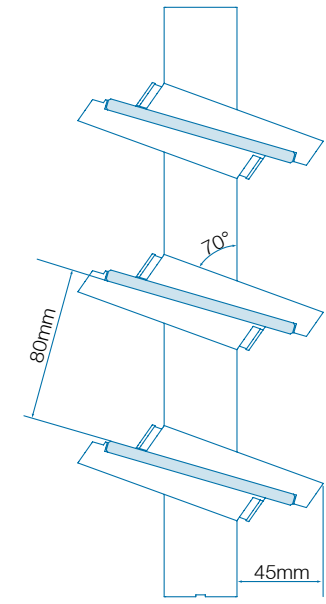

**102mm Louvre
80mm Restricted Opening**

Security Jamb: 152mm Louvres Only

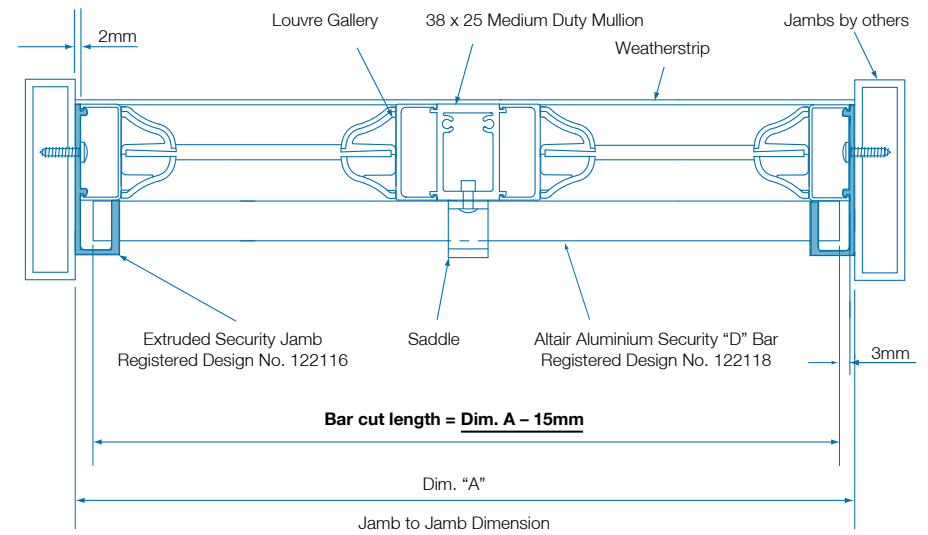
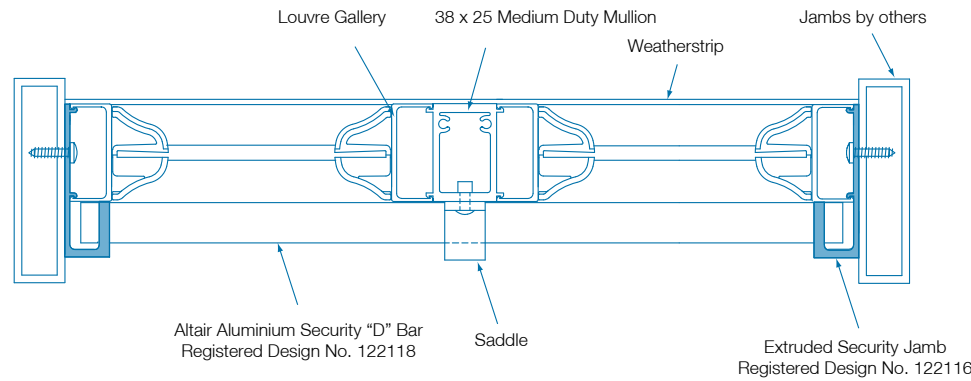

- Maximum permissible taper in jamb section is 4.0mm
- Tolerance on bar cut length to be ± 1.0 mm
- Maximum bar length unsupported is 900mm

For Alum. or Steel Jamb Section

- M5 x 10mm long Trilobular Screw
- Stainless Steel, Pan Hd. 1A Pozi-Driv
- \varnothing 4.50mm in Alum, \varnothing 4.80mm in Steel

For Timber or Masonry

- 10 Gauge x 25mm Long Self Tapping Screw
- Stainless Steel, Pan Hd. 1A Pozi-Driv

NOTES:

- See Altair® Blade Formulas for blade cut length.
- As Altair Galleries snap into Altair Security Jamb, screw holes are not required in Altair Galleries.

Altair Aluminium Security "D" Bar

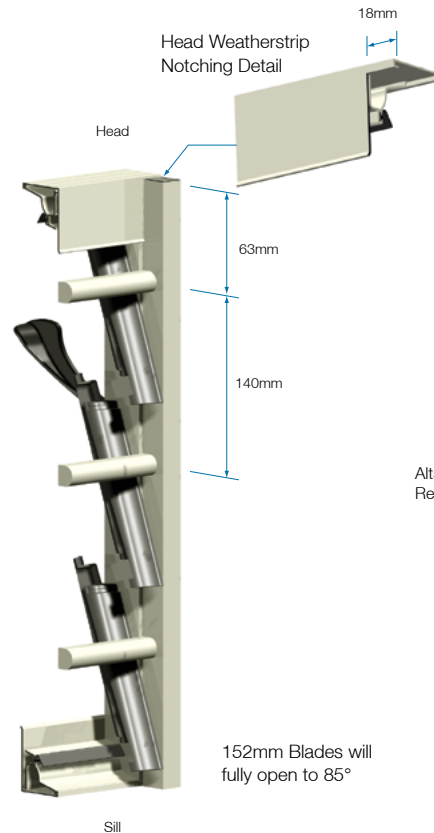
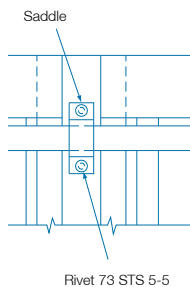
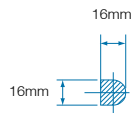

Notching Details For Security "D" Bar

Altair® Aluminium Security "D" Bar Registered Design No. 122118

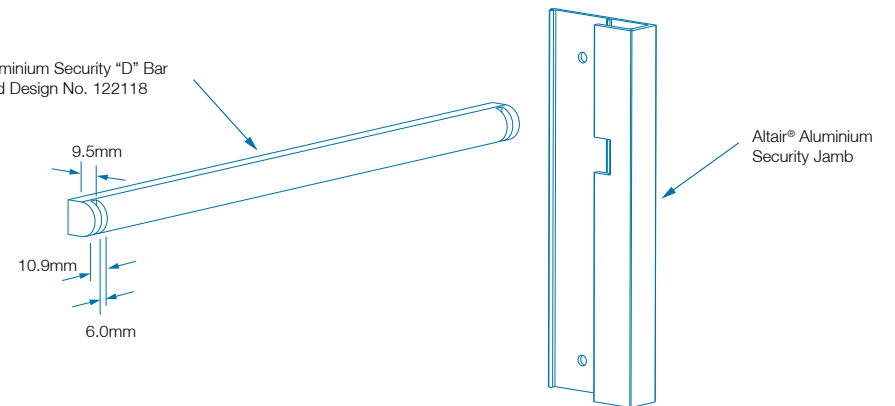

Aftermarket Security “U” Channels: 152mm Louvres Only

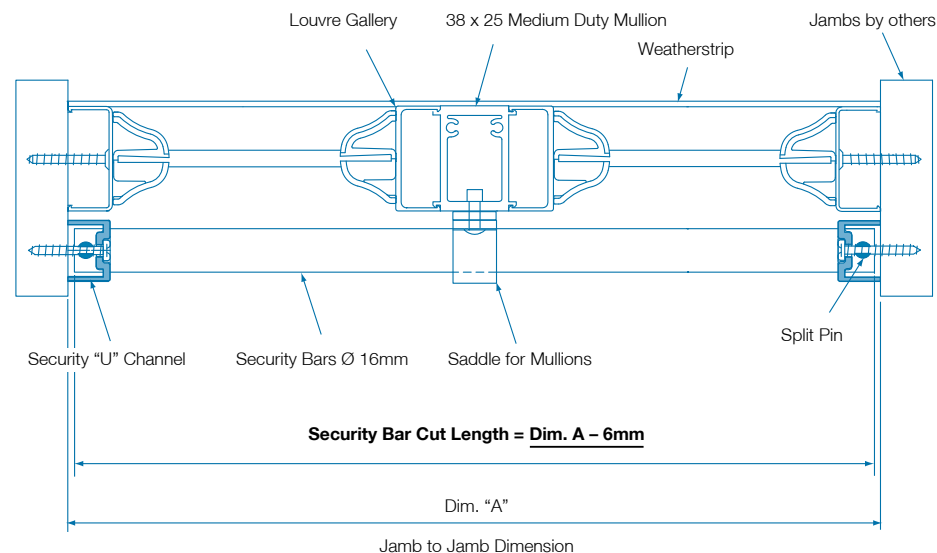
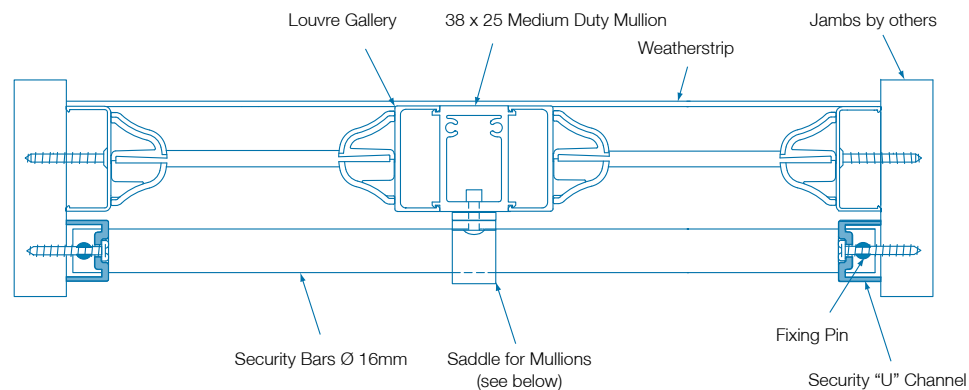

For Alum. or Steel Jamb Section

- M4 x 20mm long Trilobular Screw
- Stainless Steel, Pan Hd. 1A Pozi-Driv
- Ø 3.70mm in Alum, Ø 3.80mm in Steel

For Timber or Masonry

- 8 Gauge x 30mm Long Self Tapping Screw
- Stainless Steel, Pan Hd. 1A Pozi-Driv

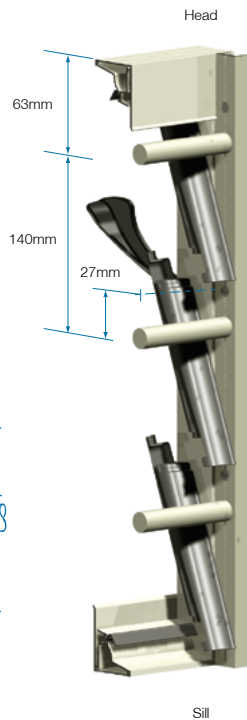
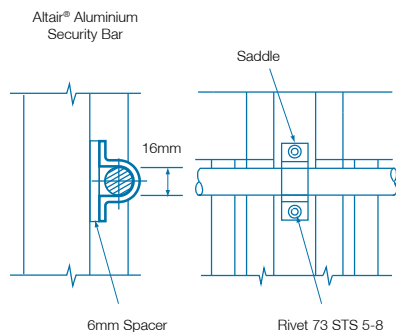

- Maximum permissible taper in jamb section is 4.0mm
- Tolerance on bar cut length to be ±1.0mm
- Maximum bar length unsupported is 900mm

Split Pin Detail For Security Round Bar

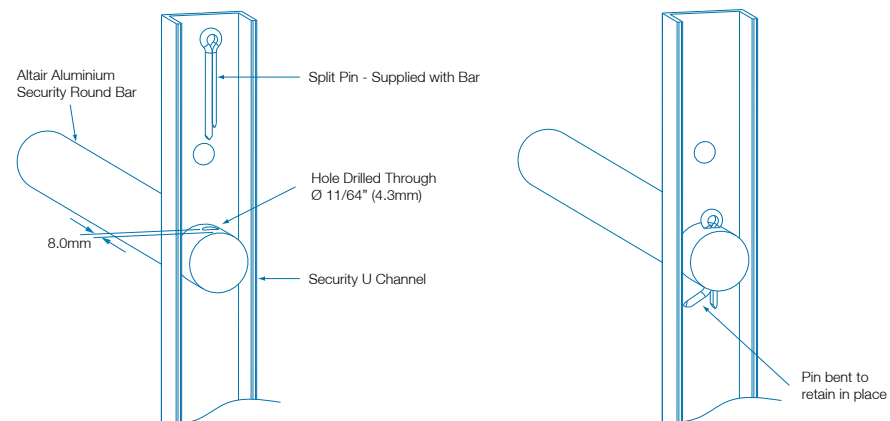

JMFNZ Timber Frame with Altair™ IGLU™ Louvre

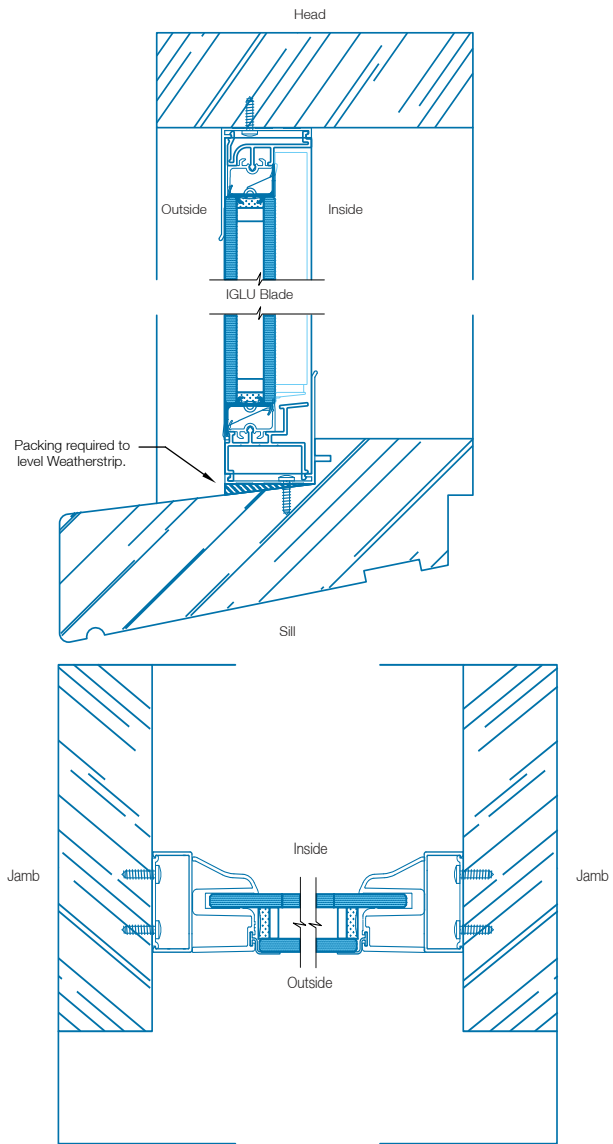

JMFNZ Timber Frame with Altair™ Louvre

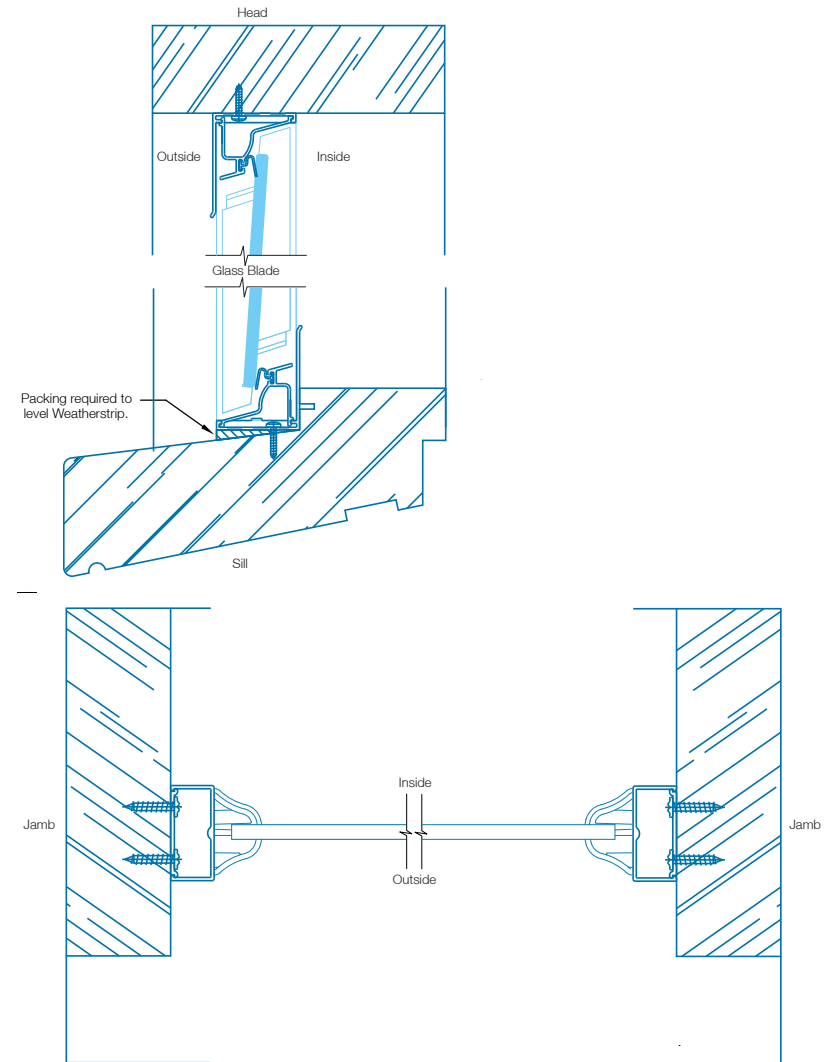

Company:	JMF NZ
Window System:	JMF NZ Timber frame using 5000 Sill
More info:	www.jmfz.co.nz
Contact:	manager@jmfz.co.nz

Checklist

REQUIRED INFORMATION viewed from inside	OPTIONAL INFORMATION
Gallery Clip Size	Left or Right Handed
Gallery Height	Restricted Opening
Gallery Colours	Handle Type
Manual or Powerlouvre® Galleries	Keylock
Clips & Handle Colour	Variable Handle Position/ Additional Handles
Blade Length & Type	Screw Holes (Ref frame, mullion, security type)
Weather strip for head & sill	Security Bar System

Recommended Specification

A tight specification will help to make sure that what you specify ends up in your building thereby achieving your design objectives.

The louvre windows shall be Breezway® Altair® Louvre Windows

Unique features:

- Unique drainage channels for superior water performance.
- Unique 'Living Hinge' design that pulls the clips tightly against the channel when closed for superior water performance and air infiltration.
- Passed testing to 40,000 open/close cycles for long operational life.
- Passed testing to 15,000 lock/unlock cycles for long operational life.
- Altair Louvres have passed AS2047 testing at 3,000mm high.

The louvre windows shall be Breezway® Altair® Powerlouvre™ Windows

Unique features:

- Unique drainage channels for superior water performance.
- Unique 'Living Hinge' design that pulls the clips tightly against the channel when closed for superior water performance and air infiltration.
- Motors are concealed within the head of the window frame.
- Motors are easily accessible for maintenance.
- Each low voltage motor only requires 0.25 amps to reduce transformer and wiring requirements.
- Motors can be powered by appropriately specified transformers from any supplier.
- Available as either a fully assembled window system or as a component system for installation into window fabricator's framing systems.

The louvre windows shall be Breezway® Altair® Louvre Windows with the Stronghold™ System

Unique features:

- Unique drainage channels for superior water performance.
- Unique 'Living Hinge' design that pulls the clips tightly against the channel when closed for superior water performance and air infiltration.
- Altair Louvres have passed testing to 40,000 open/close cycles for long operational life.
- Altair Louvres have passed testing to 15,000 lock/unlock cycles for long operational life.
- Altair Louvres have passed AS2047 testing at 3,000mm high.
- Pinned design that mechanically retains blades within the clips to prevent blade dislodgement under human impact.

The louvre windows shall be Breezway® Altair® Powerlouvre™ Windows with the Stronghold™ System

Unique features:

- Unique drainage channels for superior water performance.
- Unique 'Living Hinge' design that pulls the clips tightly against the channel when closed for superior water performance and air infiltration.
- Motors are concealed within the head of the window frame.
- Motors are easily accessible for maintenance.
- Each low voltage motor only requires 0.25 amps to reduce transformer and wiring requirements.
- Motors can be powered by appropriately specified transformers from any supplier.
- Pinned design that mechanically retains blades within the clips to prevent blade dislodgement under human impact.

Recommended Specification

A tight specification will help to make sure that what you specify ends up in your building thereby achieving your design objectives.

The louvre windows shall be Breezway® Altair® IGLU™ Louvre Windows

Unique features:

- Totally frameless double glazed louvre blades with embedded seals.
- Seal-on-seal contact between blades.
- Unique drainage channels for superior water performance.
- Pinned design that mechanically retains blades within the clips to prevent blade dislodgement under human impact.

The louvre windows shall be Breezway® Altair® Powerlouvre™ IGLU™ Louvre Windows

Unique features:

- Totally frameless double glazed louvre blades with embedded seal.
- Seal-on-seal contact between blades.
- Unique drainage channels for superior water performance.
- Motors are concealed within the head of the window frame.
- Motors are easily accessible for maintenance.
- Each low voltage motor only requires 0.4 amps to reduce transformer and wiring requirements.
- Motors can be powered by appropriately specified transformers from any supplier.
- Pinned design that mechanically retains blades within the clips to prevent blade dislodgement under human impact.

Life's better with Natural Ventilation

Breezway Head Office

35 Cambridge Street
Coorparoo QLD 4151

Tel: +61 7 3847 0500

Fax: +61 7 3397 8643

designassist@breezway.com.au

breezway.com.au

ABN 24 081 897 823

The Breezway logo features the word "breezway" in a blue, lowercase, sans-serif font. A blue arc is positioned above the letters "eez", and another blue arc is positioned below the letters "way".

breezway

Breezway®, Altair®, Stronghold®, Powerlouvre™, Easyscreen™, SL2®, Innoscreen®, Apptivate®, Dualair®, IGLU® are all trademarks of the Breezway Group of Companies.
TM denotes trademarks owned or licensed by Breezway Australia Pty Limited. Copyright owned by Breezway Australia March 2022